

PRODUCTS

Family Owned and Operated *Since 1966*

Cobra Welding Systems

Table of Contents

Customer Service	4
Terms and Conditions.....	5
Limited Warranty	6
About MK Products®	7

MIG - Push-Pull MIG Systems

Digital Power Supply and Wire Feeder

▪ CobraMig® 300	10-13
▪ CobraMig® 300 Accessories.....	12

Digital Push-Pull MIG Guns

▪ Python® X.....	14-16
▪ Spare Parts	17
▪ Cobra® X	18-20
▪ Spare Parts	21
▪ Prince® X.....	22-24
▪ Spare Parts	25

Wire Feeders

▪ Cobramatic® Pro Series	26-27
--------------------------------	-------

Push Pull MIG Guns

▪ Python®	28
▪ Air Cooled	28-31
▪ Water Cooled	32-35
▪ Spare Parts	36
▪ Python® LX	38
▪ Air Cooled	38-41
▪ Water Cooled	42-45
▪ Spare Parts	46
▪ Cobra® MX	48
▪ Air Cooled	48-51
▪ Water Cooled	52-55
▪ Spare Parts	56
▪ Prince® XL	58
▪ Air Cooled	58-61
▪ Water Cooled	62-65
▪ Spare Parts	66

Spool Guns

▪ Prince® XL.....	68-70
▪ Spare Parts	71
▪ Compatibility	72

MIG - Accessories and Consumables

▪ 3/8" Contact Tips	76
▪ 1/4" Contact Tips	77
▪ 3/8" 48° Curved Cup & Tips	78
▪ EZ-Lock® Barrels.....	79
▪ EZ-Lock® Flex Barrels	80
▪ Drive Rolls	81
▪ Barrel Liners.....	82
▪ Hard Wire	83
▪ Cobra® Times	84-85

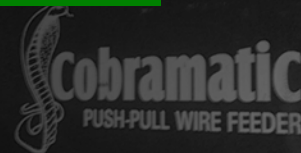

Turntables - CobraTurn® Turntables

▪ CobraTurn® T-260.....	88
▪ CobraTurn® T-30	89

Orbital - Orbital Systems

Power Supplies/ Cooler

▪ CobraTig® 150.....	94
▪ CobraCooler®	95
▪ Advanced Color Logic®	96
▪ VPAC	97

Weldheads

▪ DiamondBack®	98
▪ CopperHead®	99
▪ MiniMicro™	100
▪ Tungsten & Collets.....	102-109



**Your Customer Service
experience is important to us!**

**Customer Service Representatives are available
Monday - Friday, 6am - 5pm PST/DST**



Corporate: 949-863-1234
Toll Free: 1-800-787-9707



Website: www.mkproducts.com
Manufacturing: www.socalmfg.com



E-mail: sales@mkprod.com
Or you can submit a ticket and a representative will contact you as soon as possible.
(See details at www.mkproducts.com)



Live Chat
Live is Chat available during business hours for faster responses!
Go to www.mkproducts.com and chat with a customer service agent in real time.



Shipping
FREE UPS Truck and Ground Freight on orders over \$150 NET. (Continental USA ONLY)



MK Products® , Inc.
16882 Armstrong Ave.,
Irvine, CA 92606-4975

Supersedes All Previous Terms and Conditions of Sale

PRICING

All shipments are priced from published lists or valid quotations. Prices do not include taxes.

Prices include standard domestic packaging. For shipments that may be exported, please contact your freight forwarder for any special packaging or documentation.

PRINTED PRICES

Check all prices before ordering. The latest prices are posted on our web site at www.mkproducts.com. These prices supersede all previously published price lists. MK Products® reserves the right to make changes to these prices at any time.

INVOICE TERMS AND DISCOUNTS

Terms are NET 30 Days based on prior credit approval.

Credit card purchases using Visa, MasterCard, and American Express are accepted. Credit cards may not be used on term orders.

PAST DUE ACCOUNTS

Accounts not paid within 30 days are past due and subject to a finance charge of 1.5 % per month (annual percentage rate of 18%).

ORDER CONFIRMATION

All orders entered will immediately receive a Sales Order Acknowledgement via e-mail or fax as requested by customer.

REPAIR LABOR RATE

All repairs are billed at a rate of \$90.00 per hour.

REPAIRS/WARRANTY REPAIR

All repairs, standard or warranty, will be performed under the MK Products® Repair & Warranty Repair Policy. Full terms and conditions of this policy are available by contacting MK Products® via phone, fax, e-mail or on our website.

EDUCATIONAL DISCOUNT

An additional 25% educational discount is available on most equipment sold by MK Products®. This discount is not to be combined with any other special offer. This Educational Discount supersedes all previous publications.

TRANSFER OF TITLE

All merchandise is sold FOB MK Products® Inc., Irvine, California. Title to the merchandise transfers to the receiving party at the time carrier accepts shipment. In the event of loss or damage, it is the receiving party's responsibility to file a claim.

For assistance in reporting and filing a claim, contact MK Products Customer Service Department within 15 calendar days from the shipment

MINIMUM BILLING

Minimum billing on all domestic orders is \$35.00 USD NET.

Minimum billing on all export orders is \$100.00 USD NET.

CANCELLATION OF SALES ORDERS

Sales Orders for stocked items may be canceled at any time without charge. Upon cancellation of non-stocked line items, a fee minimum of 15% will be applied.

ORDER HANDLING

All standard UPS orders with items in stock entered by 3:00pm (PST) will be shipped the same day. For expedited orders or special requests, contact customer service at 1-800-787-9707.

MK PRODUCTS® RETURN POLICY

RMA(Return Material Authorization) All Returns MUST be accompanied by a valid RMA number

Prior to returning item(s), contact MK Products® at 1-800-787-9707 or e-mail to sales@mkprod.com, to obtain an RMA number, along with complete instructions. Please have your order number ready along with the part number and quantity of item(s) being returned. Item(s) must be returned to MK Products® within 30 calendar days of the issuance of the RMA. RMA number must be posted on the address label of the package. Packages without RMA will not be accepted by MK Products®. If applicable, MK Products® will issue credit after the item(s) has been received and inspected.

NOTE: MK Products® recommends that you: (1) use a carrier that offers shipment tracking for all returns and (2) either insure your package for safe return to MK Products® or declare the full value of the shipment so that you are completely protected if the shipment is lost or damaged in transit.

NEW/UNUSED or DEFECTIVE ITEMS

Requests for return of new/unused items must be received within 30 calendar days of original invoice. Item(s) returned unused must include original packaging and all accessories and manuals that shipped with the product. MK Products® will provide a full refund. Defective items will be credited or replaced at MK Products® discretion.

USED ITEMS

Requests for return of used items must be received within 15 calendar days of original invoice. Items returned will be subject to a minimum of 30% restocking fee and all shipping costs. Items outside the 15 day period may not qualify for return.

LIMITED WARRANTY

This warranty supersedes all previous MK Products® warranties and is exclusive, with no other guarantees or warranties expressed or implied.

LIMITED WARRANTY - MK Products® Inc., Irvine, California warrants that all new and unused equipment furnished by MK Products® is free from defects in workmanship and material. No warranty is made by MK Products® with respect to trade accessories or other items manufactured by others. Such trade accessories and other items are sold subject to the warranties of their respective manufacturers, if any.

MK Products® warranty does not apply to components having normal useful life of less than one (1) year, such as and not limited to, tungsten, collets, brushes, and welding gun parts that come in contact with the welding wire, including conduits, gas cups, gas cup insulators, and contact tips where failure does not result from defect in workmanship or material.

MK Products® shall, exclusively remedy the limited warranty or any duties with respect to the quality of goods, based upon the following options:

- (1) repair
- (2) replacement
- (3) where authorized in writing by MK Products®, the reasonable cost of repair or replacement at our Irvine, California plant.

As a matter of general policy only, MK Products® may honor an original user's warranty claims on warranted equipment in the event of failure resulting from a defect within the following periods from the date of delivery of equipment to the original user:

- 1. Power Supplies and Wire Feed Cabinets.....3 years
- 2. Weld heads, Coolers, Positioners, and Push-Pull Guns1 year
- 3. Spool Guns, and Spool Gun Modules180 days
- 4. Repairs/Exchanges/Parts90 days

Classification of any item into the foregoing categories shall be at the

sole discretion of MK Products®. Notification of any failure must be made in writing within 30 days of such failure.

A copy of the invoice showing the date of sale must accompany products returned for warranty repair or replacement.

All equipment returned to MK Products® for service must be properly packaged to guard against damage from shipping. MK Products® will not be responsible for any damages resulting from shipping.

Normal surface transportation charges (one way) for products returned for warranty repair or replacement will be borne by MK Products®, except for products sold to foreign markets.

ANY EXPRESS WARRANTY NOT PROVIDED HEREIN AND ANY IMPLIED WARRANTY, GUARANTY, OR REPRESENTATION AS TO PERFORMANCE, AND ANY REMEDY FOR BREACH OF CONTRACT WHICH, BUT FOR THIS PROVISION, MIGHT ARISE BY IMPLICATION, OPERATION OF LAW, CUSTOM OF TRADE, OR COURSE OF DEALING, INCLUDING ANY IMPLIED WARRANTY OF MERCHANTABILITY OR OF FITNESS FOR PARTICULAR PURPOSE, WITH RESPECT TO ANY AND ALL EQUIPMENT FURNISHED BY MK Products®, IS EXCLUDED AND DISCLAIMED BY MK Products®.

EXCEPT AS EXPRESSLY PROVIDED BY MK Products® IN WRITING, MK'S PRODUCTS ARE INTENDED FOR ULTIMATE PURCHASE BY COMMERCIAL/INDUSTRIAL USERS AND FOR OPERATION BY PERSONS TRAINED AND EXPERIENCED IN THE USE AND MAINTENANCE OF WELDING EQUIPMENT AND NOT FOR CONSUMERS OR CONSUMER USE. MK Products® WARRANTIES DO NOT EXTEND TO, AND NO RE-SELLER IS AUTHORIZED TO EXTEND MK Products® WARRANTIES TO ANY CONSUMER.

USE OF OTHER THAN GENUINE MK Products® CONSUMABLES, PARTS, AND ACCESSORIES MAY VOID YOUR PRODUCT WARRANTY.



AWS 1967, Live



Breaking ground in Irvine California 1972

To Our Valued Customers,

Thank you for your continued support of MK Products®! Now offering one source for all our product information and specifications, this new catalog is a quick access guide to all our products and accessories in one easy to navigate format. We hope you find this new approach helpful and easy to use.



MK's 3 Generations

Left to right (Chris Westlake, Mike Kensrue, Doug Kensrue)

MK Products® is a family owned and operated company since 1966, providing reliable and quality products to the welding industry for over 50 years. Our dedicated employees take pride in building our products right here in the United States of America! Every product is manufactured in our California facility, managed and handcrafted by employees most of which have over 20 years of experience, some with 30 years, and yes.....a number of 40+ year employees.

Whether this is your first introduction to MK Products®, or you have been using Cobra® Welding Systems for years, we are confident that you will love our product. We value your business and look forward to providing you with the best welding products and services available.

Thank you for choosing MK Products®, and as always, contact us if you have questions or need assistance. We are happy to help.

Sincerely,

Chris Westlake (3rd Generation)
President





MIG
PUSH-PULL SYSTEMS

Push-Pull MIG Systems



CobraMig®³⁰⁰ Power Supply and Detachable Aluminum Push-Pull Wire Feeder

Transform your aluminum welding with the new generation CobraMig® 300. Perfected with over 50 years of welding equipment manufacturing experience, this new roll around system features our originally patented, Push-Pull technology combined with a rock solid power supply. Detachable digital wire feeder allows separation from power supply up to 50 ft. with optional extension cables. Select your gun length and extend your reach 100 ft. or more. Designed to operate with new generation Digital X Series guns, for remote, fingertip adjustability of welding parameters without returning to feeder. Memory feature allows user to set and save eight individual programs for a variety of weld conditions. Experience the smooth stable arc of the CobraMig® 300 today.

CobraMig® 300

Duty Cycle 100%



CobraMig® 300

Model Number	187-001
--------------	---------

Key Features:

- Out of the box ready to weld
- Utilizes original patented push-pull technology
- Simple digital interface
- Compatible with next generation Plug and Play X Series Digital Push-Pull Guns
- Capable of changing all parameters and weld memories directly from the gun
- 8 fully customizable user weld memories
- Detachable digital wire feeder for rail or boom applications
- Feeder separation lengths up to 50'
- Bright LED display
- Roll around base with built in cylinder rack
- Adaptable to bulk wire systems
- Feeds .030 to 1/16 wires without changing drive rolls.
- For aluminum, steel, stainless steel, flux core wires

Specs:

- **Wire Sizes:**
 - .030" - 1/16" (0.8 mm - 1.6 mm) Aluminum Wire
 - .030" - .045" (0.8 mm - 1.2 mm) Steel, Stainless Steel, Flux Core, etc...
- **Wire Capacity:**
 - 12" Diameter Spool (plastic or wire basket)
 - Bulk Wire Drum using optional adapter kit (P/N 005-0786)
- **Power Input:**
 - 240VAC 60Hz, 50A, Single Phase
 - 480VAC 60Hz, 30A, Single Phase
- **Welding Current Output:**
 - 300A @ 60% Duty Cycle (480VAC)
- **Weight:** 245 lbs. (dry), 275 lbs (shipping)
- **Size:** 18.5" W x 34.5" H x 36" L
- **Gun Compatibility:**
 - Digital X Series Guns 14 pin: Python® X, Cobra® X, Prince® X
 - Limited functionality with 7 pin Classic Push-Pull Guns with adapter kit (P/N 005-0784)

Aluminum Welding Made Easy

Detachable Wire Feeder



- 1 **Simplified Digital User Interface** - Pressing the 'SELECT' button toggles you between Voltage, Wire Speed, and Memory position. Memory feature allows a user to set and save 8 individual programs for a variety of weld conditions
- 2 **Easy Wirefeed Setup** - Extremely easy to set up! With three intuitive adjustments, wire alloy, spool tension and wire size, you are ready to start feeding wire
- 3 **CobraLoc®**- The easy to use locking mechanism, "CobraLoc" ensures your Wire Feeder is securely locked in place on top of your Power Supply. But with a single swipe of the "CobraLoc" lever you can uncouple the detachable wire feeder allowing for unparalleled freedom of movement
- 4 **Cylinder Holder**- The handy cylinder holder is incorporated into the chassis, designed to move your gas from location to location, wherever you need your CobraMig® 300 to weld
- 5 **Wheel Around Unit**- For ease of mobility and movement around the shop, the CobraMig® 300 features a rugged 4 wheel chassis
- 6 **Plug & Play**- The New X Series Digital Push-Pull MIG Guns easily plug directly into the front of the Wire Feed portion of the CobraMig® 300
- 7 **14 Pin Amphenol**- The CobraMig® 300's 14 Pin Amphenol allows for full digital control. Thus, giving it the ability to auto sense which gun is in use, automatically adjusting the software to best match the performance of the gun

The **BEST** Push-Pull MIG Guns are now **DIGITAL!**



CobraMig® 300 | Accessories

Recommended Accessories

Quick Start Kit

15ft. Ground Cable

1GA 600V cable with alligator clamp



P/N 843-0727

Start-up Kit

Kit includes 15ft. Ground Cable and Regulator Assembly



KIT - P/N 005-0787

MK Classic Gun Connector Kit

7 to 14 Pin Adapter

Allows for connection of MK Classic Guns with 7 pin



P/N 843-0726



Connects all MK Classic Guns

KIT - P/N 005-0784

Kit includes 7 to 14 Pin Adapter and Power Pin Adapter

Limited functionality with 7 pin MK Classic Gun

Plug and Play Power Pin Adapter

Connects MK Classic Guns to power supply



P/N 003-2607

Wire Feeder Extension Cable

Extends wire feeder from power supply



P/N 003-2606-25 (25 ft.)

P/N 003-2606-35 (35 ft.)

P/N 003-2606-50 (50 ft.)

Bulk Wire Fitting 7/16"

Conduit adapter for Wire Wizard® bulk wire solutions

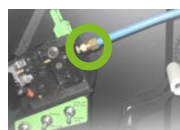

P/N 005-0786

Cable Holder Kit

2 pc. Cable Holder with hardware. Mounts to gas cylinder rack



P/N 005-0785

Molded Adapter for Wire Basket Spools

Allows for use of wire basket on CobraMig® 300



P/N 437-0340



PYTHON[®]X X Series Digital Push-Pull Gun

The Python[®] X adds a modern twist to our famous Python[®] MIG welding gun. With innovation and simplicity in mind, we are proud to present our very first digital push-pull gun which features handle mounted push buttons for your convenience. Use these buttons to easily cycle through weld settings, and quickly adjust wire speed right from the gun. And of course, everything you love about the Python[®] such as the center balanced trigger and EZ-Lock[®] 360° rotatable barrel comes standard on this gun. The Python[®] X combines the old with the new giving you a reliable, time proven gun loaded with features.

Python[®] X Duty Cycle 100%



Python [®] X	
Model Number	Length
341-815	15 ft
341-825	25 ft
341-835	35 ft
341-850	50 ft

Key Features:

- Direct Plug and Play with MK CobraMig[®] 300 system
- Digital buttons allow for complete remote control of CobraMig[®] 300
- Precision digital adjustability
- EZ-Lock[®] barrel with 360° rotation. See pg. 79 for more options
- Flex Barrel compatible. See pg. 80
- Forward trigger operation
- Ultra-Flex power cable
- CNC billet componentry
- Balanced design provides hours of continuous wire feed without welder fatigue
- Ergonomic handle
- Full range of air cooled models available in 15', 25', 35' and 50' leads
- For aluminum, steel, stainless steel, flux core wires

Specs:

- **Wire Sizes:**
 - .030" - 1/16" (0.8 mm - 1.6 mm) Aluminum Wire
 - .030" - .045" (0.8 mm - 1.2 mm) Steel, Stainless Steel, Flux Core, etc...
- **Wire Speed:**
 - 0-800 IPM (Optional 1000 IPM available P/N 211-0080)
- **Duty Cycle - 100%**
 - 225 AMPS - Air Cooled
 - All ratings using Argon Gas
- **Connections:**
 - 14 pin digital connection
 - Plug and Play power pin connection
- **Compatible Systems:**
 - CobraMig[®] 300 ONLY

Python[®]X **Air Cooled**

Gun Assembly Components - The following items are equipped on all Python[®]X Series Digital Push-Pull Guns



225 AMP 60° Curved EZ-Lock [®] Barrel	
Part Number	003-2147



Idler Roll Kit	
Part Number	005-0686

Kit includes idler roll, lock washer and screw for .030 - 1/16" wires



#10 Gas Cup - 5/8" ID	
Part Number	621-0250



Knurled Drive Roll	
Part Number	511-0101

.030 - 1/16" all wires



3/8" Spray Arc Contact Tip - .060 ID	
Part Number	621-0393-25

*Sold in packs of 25



Barrel Liner	
Part Number	931-0145

*Sold in packs of 5
.040" - 1/16" (1.0mm - 1.6mm)

See page 76-83 for additional Accessories and Consumables

Python[®]X **Air Cooled**

Gun Lead Assembly Components

Python [®] X - Lead Components					
Length	Power Cable Air Cooled	Control Cable	Gas Hose	Conduit Assembly	Snake Skin (cable cover)
15 ft	843-0640-15	005-0789-15	552-0224	615-0620-15	931-0110
25 ft	843-0640-25	005-0789-25	552-0225	615-0620-25	931-0122
35 ft	843-0640-35	005-0789-35	552-0227	615-0620-35	931-0132
50 ft	843-0640-50	005-0789-50	552-0226	615-0620-50	931-0123

For Hard Wire Welding Accessories
(Steel, Stainless Steel, Flux Core, etc...) See pg. 83

225 AMP EZ-Lock[®] Air Cooled Barrels

225 AMP barrels come with #10 gas cup (P/N 621-0250), barrel liner (P/N 931-0145) and contact tip (P/N 621-0393-25)
See barrel images on page 79

Straight Air Cooled Barrel



Straight Air Cooled Barrel	
Part Number	Length
003-2151	6 Inch
003-2156	12 inch
003-2157	18 Inch

45° Air Cooled Barrel



45° Air Cooled Barrel	
Part Number	Length
003-2152	6 Inch
003-2158	12 inch
003-2159	18 Inch

60° Air Cooled Barrel



60° Air Cooled Barrel	
Part Number	Length
003-2147	6 Inch

225 AMP EZ-Lock[®] Air Cooled Barrel - Options

Tips, Cups, Insulators, and Adapters



**Optional tip extender extends the reach of the barrel and helps protect original barrel threads*

 Cup Insulator P/N 431-1774	 Tip Extender P/N 621-0424 <i>*Optional</i>	 Contact Tip Part Numbers on pg. 76	 Gas Cup #6 P/N 621-0248 #8 P/N 621-0249 #10 P/N 621-0250 #10HD P/N 621-0251 #12HD P/N 621-0252
--	---	--	--

Spot Cup Option			
 Gas Cup Adapter P/N 003-2667	 Contact Tip Part Numbers on pg. 76	 Inside Corner P/N 621-0174	 Retaining Nut P/N 449-0193
		 Outside Corner P/N 621-0175	
		 Flat P/N 621-0176	

Python[®] X Spare Parts

Maintain optimum gun performance with genuine MK Products[®] parts. See pages 76-83 for additional Accessories and Consumables. For Hard Wire Accessories (Steel, Stainless Steel, Flux Core, etc..) See pg. 83

Trigger Kit

Includes custom molded trigger, spring, and dowel pin

P/N 005-0694



Printed Circuit Board Kit

Replaces operation buttons and circuit board on gun

P/N 005-0801

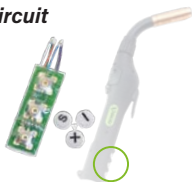

Motor

Motor assembly with leads and gear

P/N 211-0077



Micro Switch Kit

Replacement trigger switch and bracket

P/N 005-0701



Barrel Insulation Kit

Includes custom molded barrel insulator, EZ-Lock[®] retainer, and insulator ring

P/N 005-0696



Gun Door

Custom molded door for drive and idler roll compartment

P/N 437-0253



Barrel Liners

Custom molded liners for barrel

.040" - 1/16"
(1.0mm - 1.6mm)

P/N 931-0145

BULK
P/N 615-0186



Snake Skin Cover

Heat resistant lead cover

15' - 50'

15' P/N 931-0110
25' P/N 931-0122
35' P/N 931-0132
50' P/N 931-0123



Handle Kit

Kit includes right and left handle, door, and necessary hardware

P/N 005-0800



Air Cooled O-Ring Kit

All O-Rings necessary to maintain integrity of seals throughout entire gun

P/N 005-0805



Conduit Assembly

Custom Liner for Aluminium

15' - 50'

15' P/N 615-0620-15
25' P/N 615-0620-25
35' P/N 615-0620-35
50' P/N 615-0620-50



* Bulk orders for individual O-Rings available upon request



Cobra[®]X X Series Digital Push-Pull Gun Cobra[®] X | Cobra[®] X-HD

Are you ready for the future of welding? Well it has arrived in the form of the Cobra[®] X. Featuring our famous push-pull gooseneck design, and our proprietary manufacturing techniques, the Cobra[®] X brings welding to the 21st century. Save time on equipment set-up and spend more time welding with the handle-mounted push buttons making on the fly adjustments a breeze. Our lightweight design, and one click weld setting adjustments along with the performance and reliability of the Cobra[®] X makes this gun a must for anyone seeking the cutting edge in aluminum welding equipment.

Cobra[®] X
Duty Cycle 100%



Cobra[®] X-HD
Duty Cycle 100%



Cobra [®] X		Cobra [®] X-HD	
Model Number	Length	Model Number	Length
343-815	15 ft	345-815	15 ft
343-825	25 ft	345-825	25 ft
343-835	35 ft	345-835	35 ft
343-850	50 ft	345-850	50 ft

Key Features:

- Direct Plug and Play with MK CobraMig[®] 300 system
- Digital buttons allow for complete remote control of CobraMig[®] 300
- Precision digital adjustability
- Cobra fix mount barrel with high temp. barrel insulator
- Original rear trigger operation
- Ultra-Flex power cable
- CNC billet componentry
- Balanced design provides hours of continuous wire feed without welder fatigue
- Ergonomic handle
- Lightweight (weighs only 2 lbs. 5 oz.)
- Full range of air cooled models available in 15', 25', 35' and 50' leads
- For aluminum, steel, stainless steel, flux core wires

Specs:

- **Wire Sizes:**
 - .030" - 1/16" (0.8mm - 1.6 mm) Aluminum Wire
 - .030" - .045" (0.8mm - 1.2 mm) Steel, Stainless Steel, Flux Core, etc...
- **Wire Speed:**
 - 0-800 IPM (Optional 1000 IPM available P/N 211-0080)
- **Duty Cycle - 100%**
 - 175 AMPS - Air Cooled, **Cobra[®] X**
 - 200 AMPS - Air Cooled, **Cobra[®] X-HD**
 - All ratings using Argon Gas
- **Connections:**
 - 14 pin digital connection
 - Plug and Play power pin connection
- **Compatible Systems:**
 - CobraMig[®] 300 ONLY

Cobra[®]X Air Cooled

Gun Assembly Components - The following items are equipped on all Cobra[®]X Series Digital Push-Pull Guns

Cobra [®] X	Cobra [®] X-HD	SHARED
<p>Fixed A/W Barrel Part Number 003-2342</p>	<p>Fixed A/W Barrel Part Number 003-2344</p>	<p>Idler Roll Kit Part Number 005-0686 <i>Kit includes idler roll, lock washer and screw for .030 - 1/16" wires</i></p> <p>Knurled Drive Roll Part Number 511-0101 <i>.030 - 1/16" all wires</i></p> <p>Barrel Liner Part Number 931-0145 <i>*Sold in packs of 5 .040" - 1/16" (1.0mm - 1.6mm)</i></p>
<p>Gas Cup #8 Classic Part Number 001-0138-4 <i>*Sold in packs of 4</i></p>	<p>Gas Cup #8 HD Part Number 621-0421</p>	
<p>Tip 1/4" X .060 ID Spray Arc Part Number 621-0003-25 <i>*Sold in packs of 25</i></p>	<p>Tip 3/8" X .060 ID HD Spray Arc Part Number 621-0393-25 <i>*Sold in packs of 25</i></p>	

See page 76-83 for additional Accessories and Consumables

Cobra[®]X Air Cooled

Gun Lead Assembly Components

Cobra [®] X & Cobra [®] X-HD Lead Components					
Length	Power Cable Air Cooled	Control Cable	Gas Hose	Conduit Assembly	Snake Skin (cable cover)
15 ft	843-0640-15	005-0789-15	552-0224	615-0620-15	931-0110
25 ft	843-0640-25	005-0789-25	552-0225	615-0620-25	931-0122
35 ft	843-0640-35	005-0789-35	552-0227	615-0620-35	931-0132
50 ft	843-0640-50	005-0789-50	552-0226	615-0620-50	931-0123

For Hard Wire Welding Accessories
(Steel, Stainless Steel, Flux Core, etc...) See pg. 83

Cobra[®]X - Barrel Options - 175 AMP Air Cooled

Tips, Cups, Insulators, and Adapters



** Optional tip extender extends the reach of the barrel and helps protect original barrel threads*

<p>Tip Extender P/N 621-0017 stackable up to 5 *Optional</p>	<p>Contact Tip 1/4" Spray Arc Part Numbers on pg. 77</p>	<p>Gas Cup #5 P/N 621-0079 #6 P/N 001-0137-4 #8 P/N 001-0138-4 #10 P/N 001-0139-4</p>
--	---	--

Finned Cup, 3/8" Tip Adapter Option

<p>3/8" Tip Adapter P/N 431-1630</p>	<p>Tip Extender P/N 621-0424</p>	<p>Contact Tip 3/8" Spray Arc Part Numbers on pg. 76</p>	<p>Finned Gas Cup #6 P/N 621-0248 #8 P/N 621-0249 #10 P/N 621-0250 #10HD P/N 621-0251 #12HD P/N 621-0252</p>
---	---	---	---

Fixed Barrel HD Gas Cup, 3/8" Tip Adapter Option

<p>3/8" Tip Adapter P/N 003-2210</p>	<p>Tip Extender P/N 621-0423 stackable up to 5 *Optional</p>	<p>Contact Tip 3/8" Spray Arc Part Numbers on pg. 76</p>	<p>HD Gas Cup #6 P/N 621-0420 #8 P/N 621-0421 #10 P/N 621-0422</p>
---	--	---	---

Spot Cup Option

<p>Contact Tip 1/4" Spray Arc Part Numbers on pg. 77</p>	<p>Spot Cup Adapter P/N 001-0545</p>	<p>Inside Corner P/N 621-0197</p>	<p>Outside Corner P/N 621-0199</p>	<p>Retaining Nut P/N 449-0193</p>
		<p>Flat P/N 621-0198</p>		

Cobra[®]X-HD Barrel Options - 200 AMP Air Cooled

Tips, Cups, Insulators, and Adapters



** Optional tip extender extends the reach of the barrel and helps protect original barrel threads*

<p>Tip Extender P/N 621-0423 stackable up to 5 *Optional</p>	<p>Contact Tip 3/8" Spray Arc Part Numbers on pg. 76</p>	<p>HD Gas Cup #6 P/N 621-0420 #8 P/N 621-0421 #10 P/N 621-0422</p>
--	---	---

Spot Cup Option

<p>Contact Tip 3/8" Spray Arc Part Numbers on pg. 76</p>	<p>Gas Cup Adapter P/N 003-2665</p>	<p>Inside Corner P/N 621-0197</p>	<p>Outside Corner P/N 621-0199</p>	<p>Retaining Nut P/N 449-0193</p>
		<p>Flat P/N 621-0198</p>		

Cobra[®] X & Cobra[®] X-HD Spare Parts

Maintain optimum gun performance with genuine MK Products[®] parts. See pages 76-83 for additional Accessories and Consumables. For Hard Wire Accessories (Steel, Stainless Steel, Flux Core, etc..) See pg. 83

Trigger Kit

Includes custom molded trigger, spring, and dowel pin



P/N 005-0694

Printed Circuit Board Kit

Replaces operation buttons and circuit board on gun

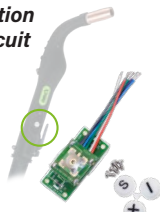

P/N 005-0791

Gun Door

Custom molded door for drive and idler roll compartment



P/N 437-0253

Motor

Motor assembly with leads and gear



P/N 211-0085

Micro Switch

Replacement trigger switch and bracket



P/N 003-2274

Barrel Insulator

Custom molded insulator for barrel



P/N 437-0299

Barrel Liners

Custom molded liners for barrel

.040" - 1/16"
(1.0mm - 1.6mm)

P/N 931-0145

BULK
P/N 615-0186



* Sold in packs of 5

Snake Skin Cover

Heat resistant lead cover

15' - 50'

15' P/N 931-0110

25' P/N 931-0122

35' P/N 931-0132

50' P/N 931-0123



Handle Kit

Kit includes right and left handle, door, and necessary hardware

P/N 005-0790



Fixed Barrel O-Ring Kit

All O-Rings necessary to maintain integrity of seals throughout entire gun

P/N 005-0807



* Bulk orders for individual O-Rings available upon request

Conduit Assembly

Custom Liner for Aluminium

15' - 50'

15' P/N 615-0620-15

25' P/N 615-0620-25

35' P/N 615-0620-35

50' P/N 615-0620-50



PRINCE[®]X

X Series Digital Push-Pull Gun

The Prince[®] X presents a new take on our highly popular Prince[®] XL push-pull gun. Offering the same reliability as the Prince[®] XL, the Prince[®] X promises to outperform and outlast the competition with game changing digital control. With push buttons mounted on the base of the handle, you are now able to scroll through weld settings as well as execute incremental adjustments remotely from the gun. Times are changing, and with the Prince[®] X you will now be able to keep up.



Prince[®] X
Duty Cycle 100%

225
A
M
P
S
A/C

Prince [®] X	
Model Number	Length
350-715	15 ft
350-725	25 ft
350-735	35 ft
350-750	50 ft

Key Features:

- Direct Plug and Play with MK CobraMig[®] 300 system
- Digital buttons allow for complete remote control of CobraMig[®] 300
- Precision digital adjustability
- EZ-Lock[®] barrel with 360° rotation. See pg. 79 for more options
- Flex Barrel compatible. See pg. 80
- Pistol grip style gun
- Ultra-Flex power cable
- CNC billet componentry
- Balanced design provides hours of continuous wire feed without welder fatigue
- Ergonomic handle
- Full range of air cooled models available in 15', 25', 35' and 50' leads
- For aluminum, steel, stainless steel, flux core wires

Specs:

- **Wire Sizes:**
 - .030 - 1/16" (0.8 mm - 1.6 mm) Aluminum Wire
 - .030" - .045" (0.8 mm - 1.2 mm) Steel, stainless steel, flux core, etc...
- **Wire Speed:**
 - 0-800 IPM
- **Duty Cycle - 100%**
 - 225 AMPS - Air Cooled
 - All ratings using Argon Gas
- **Connections:**
 - 14 pin digital connection
 - Plug and Play power pin connection
- **Compatible Systems:**
 - CobraMig[®] 300 ONLY

Prince[®] X **Air Cooled**

Gun Assembly Components - The following items are equipped on all Prince[®] X Series Digital Push-Pull Guns



225 AMP Straight EZ-Lock Barrel	
Part Number	003-2151



Idler Roll Kit	
Part Number	005-0686

Kit includes idler roll, lock washer and screw for .030 - 1/16" wires



#10 Gas Cup - 5/8" ID	
Part Number	621-0250



Knurled Drive Roll	
Part Number	511-0101

.030 - 1/16" all wires



3/8" Spray Arc Contact Tip - .060 ID	
Part Number	621-0393-25

*Sold in packs of 25



Barrel Liner	
Part Number	931-0145

*Sold in packs of 5
.040" - 1/16" (1.0mm - 1.6mm)

See page 76-83 for additional Accessories and Consumables

Prince[®] X **Air Cooled**

Gun Lead Assembly Components

Prince [®] X - Lead Components					
Length	Power Cable Air Cooled	Control Cable	Gas Hose	Conduit Assembly	Snake Skin (cable cover)
15 ft	843-0619	005-0789-15	552-0224	615-0620-15	931-0110
25 ft	843-0620	005-0789-25	552-0225	615-0620-25	931-0122
35 ft	843-0622	005-0789-35	552-0227	615-0620-35	931-0132
50 ft	843-0621	005-0789-50	552-0226	615-0620-50	931-0123

For Hard Wire Welding Accessories
(Steel, Stainless Steel, Flux Core, etc...) See pg. 83

225 AMP EZ-Lock[®] Air Cooled Barrels

225 AMP barrels come with #10 gas cup (P/N 621-0250), barrel liner (P/N 931-0145) and contact tip (P/N 621-0393-25)
See barrel images on page 79

Straight Air Cooled Barrel



Straight Air Cooled Barrel	
Part Number	Length
003-2151	6 Inch
003-2156	12 inch
003-2157	18 Inch

45° Air Cooled Barrel







45° Air Cooled Barrel	
Part Number	Length
003-2152	6 Inch
003-2158	12 inch
003-2159	18 Inch







225 AMP EZ-Lock[®] Air Cooled Barrel - Options

Tips, Cups, Insulators, and Adapters



**Optional tip extender extends the reach of the barrel and helps protect original barrel threads*

 Cup Insulator P/N 431-1774	 Tip Extender P/N 621-0424 <i>*Optional</i>	 Contact Tip Part Numbers on pg. 76	 Gas Cup #6 P/N 621-0248 #8 P/N 621-0249 #10 P/N 621-0250 #10HD P/N 621-0251 #12HD P/N 621-0252
---	--	---	---

Spot Cup Option			
 Gas Cup Adapter P/N 003-2667	 Contact Tip Part Numbers on pg. 76	 Inside Corner P/N 621-0174	 Retaining Nut P/N 449-0193
		 Outside Corner P/N 621-0175	
		 Flat P/N 621-0176	

Prince[®] X Spare Parts

Maintain optimum gun performance with genuine MK Products[®] parts. See pages 76-83 for additional Accessories and Consumables. For Hard Wire Accessories (Steel, Stainless Steel, Flux Core, etc..) See pg. 83

Trigger Kit

Includes custom molded trigger, pin spring, and dowel pin

P/N 005-0550



Printed Circuit Board Kit

Replaces operation buttons and circuit board on gun

P/N 005-0802

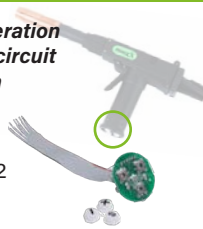

Motor

Motor assembly with leads and gear

P/N 211-0071



Micro Switch

Replacement trigger switch and bracket

P/N 003-2632

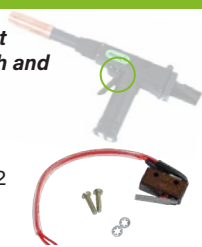

Barrel Insulation Kit

Includes custom molded barrel insulator, EZ-Lock[®] retainer, and insulator ring

P/N 005-0696

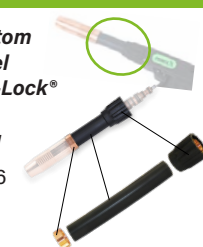

Gun Door

Custom molded door for drive and idler roll compartment

P/N 431-3117



Barrel Liners

Custom molded liners for barrel

.040" - 1/16"
(1.0mm - 1.6mm)

P/N 931-0145

BULK
P/N 615-0186



* Sold in packs of 5

Snake Skin Cover

Heat resistant lead cover

15' - 50'

15' P/N 931-0110
25' P/N 931-0122
35' P/N 931-0132
50' P/N 931-0123



Handle Kit

Kit includes right and left handle, door, and necessary hardware

P/N 005-0788



Air Cooled O-Ring Kit

All O-Rings necessary to maintain integrity of seals throughout entire gun

P/N 005-0805



* Bulk orders for individual O-Rings available upon request

Conduit Assembly

Custom Liner for Aluminium

15' - 50'

15' P/N 615-0620-15
25' P/N 615-0620-25
35' P/N 615-0620-35
50' P/N 615-0620-50



Cobramatic® Pro Series Wire Feeder

From its conception over 50 years ago, the welding industry has recognized the Cobramatic® Wire Feeder as the standard in which all other feeders compare. Today, and after many refinements, MK Products® continues its tradition with the Cobramatic® Pro Series Wire Feeder. Optional adapter cables allow most CV/CC power supplies to connect with ease. Operates flawlessly with most synergic power supplies. Combined with MK push-pull guns, the Cobramatic® Pro Series Wire Feeder guarantees to provide the best and most versatile solution for smoothly feeding many types of aluminum, and hard wires.



Cobramatic® Pro Series

Model Number	150-007-M
--------------	-----------

It's hard to find a Power Supply that our Cobramatic® Pro Series Wire Feeder **doesn't** connect to

Key Features:

- Compatible with air and water cooled MK analog guns
- Incorporates originally patented wire feed technology
- Compact design. Fits through ship portholes
- Rugged all-weather case
- Bright LED panel
- Voltage and wire speed display
- Plug and Play interface cable kits for most power supplies
- Adaptable to bulk wire systems
- Feeds .030 to 1/16 wires without changing drive rolls.
- For aluminum, steel, stainless steel, flux core wires

Specs:

- **Wire Sizes:**
 - .030" - 1/16" (0.8 mm - 1.6 mm) Aluminum Wire
 - .030" - .045" (0.8 mm - 1.2 mm) Steel, Stainless Steel, Flux Core, etc...
- **Wire Capacity:**
 - 12" Diameter Spool
 - Bulk wire drum using optional adapter kit (P/N 005-0786)
- **Power Input:**
 - 230/115/42/30 VAC 50/60 Hz Single Phase
- **Weight:**
 - 30 lbs (shipped)
- **Unit Size:**
 - 21"L x 16"H x 8"W



Connect any MK Products® Push-Pull MIG Gun!



Python®

Air Cooled - P/N 234-8XX (pg. 28)
Water Cooled - P/N 235-8XX (pg. 32)



Python® LX

Air Cooled - P/N 260-8XX (pg. 38)
Water Cooled - P/N 261-8XX (pg. 42)



Cobra® MX

Air Cooled - P/N 266-8XX (pg. 48)
Water Cooled - P/N 262-8XX (pg. 52)

HD Air Cooled - P/N 267-8XX (pg. 48)
HD Water Cooled - P/N 263-8XX (pg. 52)



Prince® XL

Air Cooled - P/N 317-7XX (pg. 58)
Water Cooled - P/N 318-7XX (pg.62)



Connects to any of these power supplies & MORE!
Call factory for details

Plug and Play Interface Cable Kits

Part Number	Description	Part Number	Description
005-0316	8 ft. Interface cable for Miller, 14 pin, 115VAC	005-0658-50	50 ft. Interface cable for Miller, 14 pin, 115VAC
005-0608	8 ft. Interface cable for Lincoln, 14 pin, 115VAC	005-0659-50	50 ft. Interface cable for Lincoln, 14 pin, 115VAC
005-0658	25 ft. Interface cable for Miller, 14 pin, 115VAC	005-0630	8 ft. Interface cable for Thermal Arc, 19 Pin 115VAC
005-0659	25 ft. Interface cable for Lincoln, 14 pin, 115VAC	005-0705	8 ft. Interface cable for ESAB 460/450 115VAC



PYTHON[®]

Air Cooled

When you combine power, performance, and reliability, you get the Python[®]. Recognized throughout the industry as the most advanced aluminum push-pull gun available, the Python[®] continues its tradition with unparalleled performance. Time tested rugged design developed to withstand the rigors of industrial production and provide hours of smooth wire feeding operation. When it comes to aluminum welding, the Python[®] is your answer.

Python[®]

Duty Cycle 100%

225
A
M
P
S
A/C

Key Features:

- EZ-Lock[®] barrel with 360° degree rotation. See pg. 79 for more options
- Flex Barrel compatible. See pg. 80
- Forward trigger operation
- Right or left hand wire feed adjustment protected in the handle
- CNC billet componentry
- Ultra-Flex power cable
- Balanced design provides hours of continuous wire feed without welder fatigue
- Ergonomic handle
- Full range of models available in 15', 25', 35' and 50' leads
- For aluminum, steel, stainless steel, flux core wires

Specs:

- **Wire Size:**
 - .030" - 1/16" (0.8 mm - 1.6 mm) Aluminum
 - .030" - .045" (0.8 mm - 1.2 mm) Steel, Stainless Steel, Flux Core, etc...
- **Wire Speed:**
 - 0-800 IPM (Optional 1000 IPM available *P/N 211-0080*)
- **Duty Cycle - 100%**
 - 225 AMPS - Air Cooled
 - All ratings using Argon Gas
- **Connections:**
 - MK Products[®] 7 Pin, Lincoln 7 Pin, Miller 10 Pin, Fronius 9 Pin

Python® Air Cooled

Compatible OEM Connections - All compatible guns use genuine MK Product® consumables. Choose one of our Plug and Play direct connections below



MK Products® Compatibility	
Length	Model Number
15 ft	234-815
25 ft	234-825
35 ft	234-835
50 ft	234-850



Lincoln®, 7 Pin Compatibility	
Length	Model Number
15 ft	232-815
25 ft	232-825
35 ft	232-835
50 ft	232-850

12 Pin Lincoln connection use adapter (P/N 843-0679)



Miller®, 10 Pin Compatibility	
Length	Model Number
15 ft	291-815
25 ft	291-825
35 ft	291-835
50 ft	291-850



Fronius®, 9 Pin	
Length	Model Number
15 ft	289-815
25 ft	289-825
35 ft	289-835
50 ft	289-850

Python® Air Cooled

Gun Assembly Components - The following items are equipped on all Python® Air Cooled Models



225 AMP 60° Curved EZ-Lock® Barrel	
Part Number	003-2147



Idler Roll Kit	
Part Number	005-0686

Kit includes idler roll, lock washer and screw for .030" - 1/16" wires



#10 Gas Cup - 5/8" ID	
Part Number	621-0250



Knurled Drive Roll	
Part Number	511-0101

.030" - 1/16" all wires



3/8" Spray Arc Contact Tip - .060 ID	
Part Number	621-0393-25

*Sold in packs of 25



Barrel Liner	
Part Number	931-0145

*Sold in packs of 5
.040" - 1/16" (1.0mm - 1.6mm)

See page 76-83 for additional Accessories and Consumables

 **Python[®] Air Cooled**
Gun Lead Assembly Components

MK Products [®] Compatible					
Length	Power Cable Air Cooled	Control Cable	Gas Hose	Conduit Assembly	Snake Skin (cable cover)
15 ft	843-0630-15	005-0690	552-0242-15	615-0601-15	931-0110
25 ft	843-0630-25	005-0691	552-0242-25	615-0601-25	931-0122
35 ft	843-0630-35	005-0740	552-0242-35	615-0601-35	931-0132
50 ft	843-0630-50	005-0692	552-0242-50	615-0601-50	931-0123

Lincoln [®] , 7 Pin Compatibility					
Length	Power Cable Air Cooled	Control Cable	Gas Hose	Conduit Assembly	Snake Skin (cable cover)
15 ft	843-0640-15	005-0690	552-0241-15	615-0620-15	931-0110
25 ft	843-0640-25	005-0691	552-0241-25	615-0620-25	931-0122
35 ft	843-0640-35	005-0740	552-0241-35	615-0620-35	931-0132
50 ft	843-0640-50	005-0692	552-0241-50	615-0620-50	931-0123

Miller [®] , 10 Pin Compatibility					
Length	Power Cable Air Cooled	Control Cable	Gas Hose	Conduit Assembly	Snake Skin (cable cover)
15 ft	843-0640-15	005-0380-15	552-0241-15	615-0620-15	931-0110
25 ft	843-0640-25	005-0380-25	552-0241-25	615-0620-25	931-0122
35 ft	843-0640-35	005-0380-35	552-0241-35	615-0620-35	931-0132
50 ft	843-0640-50	005-0380-50	552-0241-50	615-0620-50	931-0123

Fronius [®] , 9 Pin Compatibility					
Length	Power Cable Air Cooled	Control Cable	Gas Hose	Conduit Assembly	Snake Skin (cable cover)
15 ft	843-0640-15	005-0381-15	552-0241-15	615-0620-15	931-0110
25 ft	843-0640-25	005-0381-25	552-0241-25	615-0620-25	931-0122
35 ft	843-0640-35	005-0381-35	552-0241-35	615-0620-35	931-0132
50 ft	843-0640-50	005-0381-50	552-0241-50	615-0620-50	931-0123

**For Hard Wire Welding Accessories
 (Steel, Stainless Steel, Flux Core, etc...) See pg. 83**

225 AMP EZ-Lock[®] Air Cooled Barrels

225 AMP barrels come with #10 gas cup (P/N 621-0250), barrel liner (P/N 931-0145) and contact tip (P/N 621-0393-25)
See barrel images on page 79

Straight Air Cooled Barrel



Straight Air Cooled Barrel	
Part Number	Length
003-2151	6 Inch
003-2156	12 inch
003-2157	18 Inch

45° Air Cooled Barrel



45° Air Cooled Barrel	
Part Number	Length
003-2152	6 Inch
003-2158	12 inch
003-2159	18 Inch

60° Air Cooled Barrel



60° Air Cooled Barrel	
Part Number	Length
003-2147	6 Inch

225 AMP EZ-Lock[®] Air Cooled Barrel - Options

Tips, Cups, Insulators, and Adapters



Clip
P/N 313-0133

**Optional tip extender extends the reach of the barrel and helps protect original barrel threads*

Cup Insulator P/N 431-1774	Tip Extender P/N 621-0424 <i>*Optional</i>	Contact Tip Part Numbers on pg. 76	Gas Cup #6 P/N 621-0248 #8 P/N 621-0249 #10 P/N 621-0250 #10HD P/N 621-0251 #12HD P/N 621-0252

Spot Cup Option			
Gas Cup Adapter P/N 003-2667	Contact Tip Part Numbers on pg. 76	Inside Corner P/N 621-0174	Retaining Nut P/N 449-0193
		Outside Corner P/N 621-0175	
		Flat P/N 621-0176	

PYTHON[®]

Water Cooled

Does your application require long duty cycles at a high output? If so, then look no further than the Water Cooled Python[®], with a 400 amp rated output at 100% duty cycle. Recognized throughout the industry as the most advanced aluminum push-pull gun available, the water-cooled Python[®] continues its tradition with unparalleled performance. Time tested rugged design developed to withstand the rigors of heavy industrial production and provide hours of smooth wire feeding operation. When it comes to aluminum welding, the Python[®] is your answer.



Python[®]
Duty Cycle 100%



Key Features:

- EZ-Lock[®] barrel with 360° rotation. See pg. 79 for more options
- Forward trigger operation
- Right or left hand wire feed adjustment protected in the handle
- CNC billet componentry
- Ultra-Flex power cable
- Balanced design provides hours of continuous wire feed without welder fatigue
- Ergonomic handle
- Full range of models available in 15', 25', 35' and 50' leads
- For aluminum, steel, stainless steel, flux core wires

Specs:

- **Wire Size:**
 - .030" - 1/16" (0.8 mm - 1.6 mm) Aluminum Wire
 - .030" - .045" (0.8 mm - 1.2 mm) Steel, Stainless Steel, Flux Core, etc...
- **Wire Speed:**
 - 0-800 IPM (Optional 1000 IPM available *P/N 211-0080*)
- **Duty Cycle - 100%**
 - 400 AMPS - Water Cooled
 - All ratings using Argon Gas
- **Connections:**
 - MK Products[®] 7 Pin, Lincoln 7 Pin, Miller 10 Pin, Fronius 9 Pin

For BEST performance, use our Cobra[®] Coolant!
Failure to use Cobra[®] Coolant may void warranty



1 Gallon (3.78L)	
Part Number	931-0060

1 Case (4Gal / 1Gal ea.)	
Part Number	931-0060-4

5 Gallon (18.9L)	
Part Number	931-0060-5GAL

Python® Water Cooled

Compatible OEM Connections - All compatible guns use genuine MK Product consumables. Choose one of our Plug and Play direct connections below



MK Products® Compatibility	
Length	Model Number
15 ft	235-815
25 ft	235-825
35 ft	235-835
50 ft	235-850



Lincoln®, 7 Pin Compatibility	
Length	Model Number
15 ft	293-815
25 ft	293-825
35 ft	293-835
50 ft	293-850

12 Pin Lincoln connection use adapter (P/N 843-0679)



Miller®, 10 Pin Compatibility	
Length	Model Number
15 ft	292-815
25 ft	292-825
35 ft	292-835
50 ft	292-850



Fronius®, 9 Pin Compatibility	
Length	Model Number
15 ft	290-815
25 ft	290-825
35 ft	290-835
50 ft	290-850

Python® Water Cooled

Gun Assembly Components - The following items are equipped on all Python® Water Cooled Models



400 AMP 60° Curved EZ-Lock® Barrel	
Part Number	003-2317



Idler Roll Kit	
Part Number	005-0686

Kit includes idler roll, lock washer and screw for .030" - 1/16" wires



#10 Gas Cup - 5/8" ID	
Part Number	621-0065



Knurled Drive Roll	
Part Number	511-0101

.030" - 1/16" all wires



3/8" Spray Arc Contact Tip - .060 ID	
Part Number	621-0393-25

*Sold in packs of 25



Barrel Liner	
Part Number	931-0145

*Sold in packs of 5
.040" - 1/16" (1.0mm - 1.6mm)

See page 76-83 for additional Accessories and Consumables

Python[®] **Water Cooled**
Gun Lead Assembly Components

MK Products [®] Compatibility						
Length	Power Cable Water Cooled	Water Hose Return (BLUE)	Control Cable	Gas Hose	Conduit Assembly	Snake Skin (cable cover)
15 ft	005-0387-15	552-0243-15	005-0690	552-0242-15	615-0601-15	931-0110
25 ft	005-0387-25	552-0243-25	005-0691	552-0242-25	615-0601-25	931-0122
35 ft	005-0387-35	552-0243-35	005-0740	552-0242-35	615-0601-35	931-0132
50 ft	005-0387-50	552-0243-50	005-0692	552-0242-50	615-0601-50	931-0123

Lincoln [®] , 7 Pin Compatibility							
Length	Power Cable Water Cooled	Water Hose Return (BLUE)	Water Hose Return (RED)	Control Cable	Gas Hose	Conduit Assembly	Snake Skin (cable cover)
15 ft	005-0388-15	552-0239-15	552-0209	005-0690	552-0241-15	615-0620-15	931-0110
25 ft	005-0388-25	552-0239-25		005-0691	552-0241-25	615-0620-25	931-0122
35 ft	005-0388-35	552-0239-35		005-0740	552-0241-35	615-0620-35	931-0132
50 ft	005-0388-50	552-0239-50		005-0692	552-0241-50	615-0620-50	931-0123

Miller [®] , 10 Pin Compatibility							
Length	Power Cable Water Cooled	Water Hose Return (BLUE)	Water Hose Return (RED)	Control Cable	Gas Hose	Conduit Assembly	Snake Skin (cable cover)
15 ft	005-0388-15	552-0239-15	552-0209	005-0380-15	552-0241-15	615-0620-15	931-0110
25 ft	005-0388-25	552-0239-25		005-0380-25	552-0241-25	615-0620-25	931-0122
35 ft	005-0388-35	552-0239-35		005-0380-35	552-0241-35	615-0620-35	931-0132
50 ft	005-0388-50	552-0239-50		005-0380-50	552-0241-50	615-0620-50	931-0123

Fronius [®] , 9 Pin Compatibility							
Length	Power Cable Water Cooled	Water Hose Return (BLUE)	Water Hose Return (RED)	Control Cable	Gas Hose	Conduit Assembly	Snake Skin (cable cover)
15 ft	005-0388-15	552-0238-15	552-0211	005-0381-15	552-0241-15	615-0620-15	931-0110
25 ft	005-0388-25	552-0238-25		005-0381-25	552-0241-25	615-0620-25	931-0122
35 ft	005-0388-35	552-0238-35		005-0381-35	552-0241-35	615-0620-35	931-0132
50 ft	005-0388-50	552-0238-50		005-0381-50	552-0241-50	615-0620-50	931-0123

**For Hard Wire Welding Accessories
(Steel, Stainless Steel, Flux Core, etc...) See pg. 83**

400 AMP EZ-Lock® Water Cooled Barrels

400 AMP barrels come with #10 full water cooled cup (P/N 621-0065), barrel liner (P/N 931-0145) and contact tip (P/N 621-0393-25)
See barrel images on page 79

Straight Water Cooled Barrel



Straight W\C Barrel	
Part Number	Length
003-2315	6 Inch
003-2318	12 inch
003-2320	18 Inch

45° Water Cooled Barrel



45° Water Cooled Barrel	
Part Number	Length
003-2316	6 Inch
003-2319	12 inch
003-2321	18 Inch

60° Water Cooled Barrel



60° Water Cooled Barrel	
Part Number	Length
003-2317	6 Inch

Water Cooled Barrels Options

Tips, Cups, Insulators, and Adapters

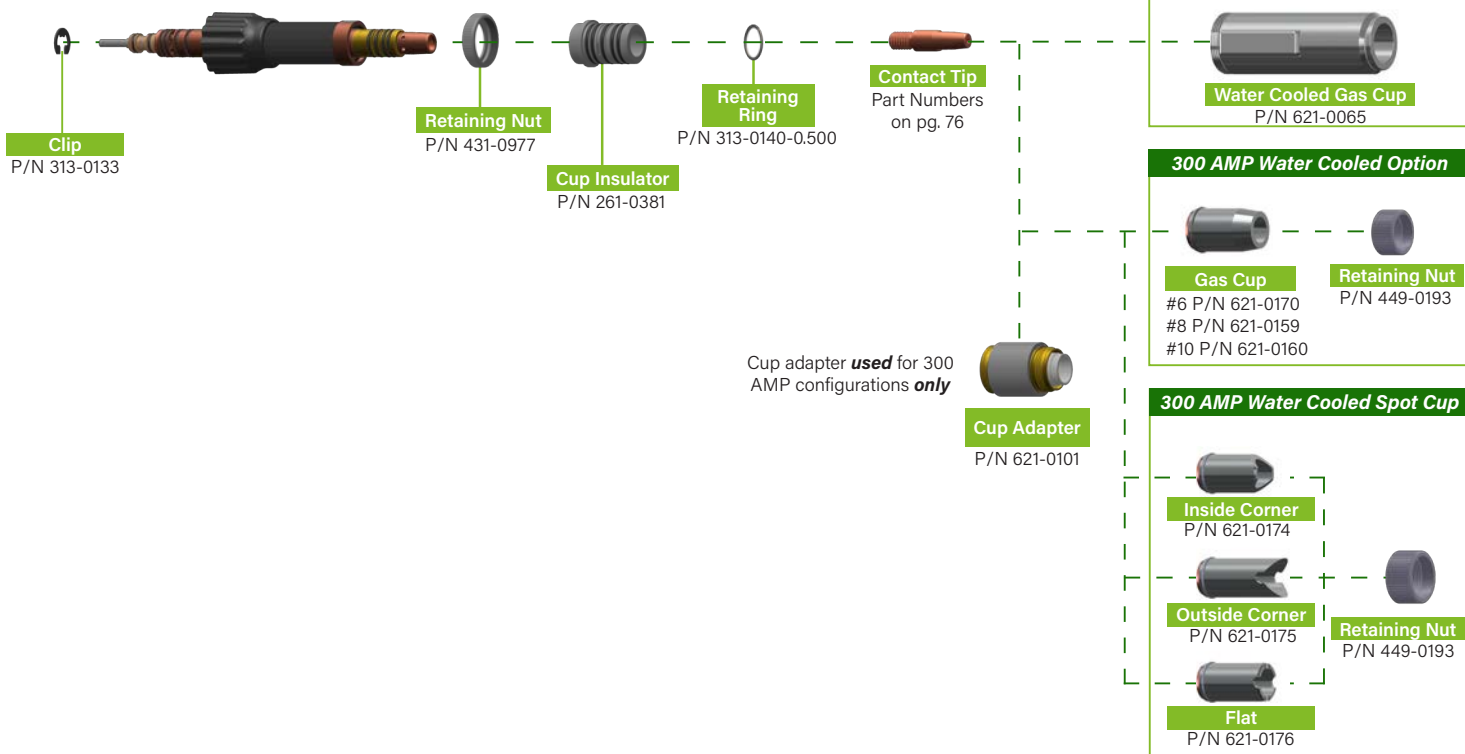

Python[®] Air & Water Spare Parts

Maintain optimum gun performance with genuine MK Products[®] parts. See pages 76-83 for additional Accessories and Consumables. For Hard Wire Accessories (Steel, Stainless Steel, Flux Core, etc..) See pg. 83

Trigger Kit

Kit includes custom molded trigger, spring, and dowel pin

P/N 005-0694



Potentiometer Assy Kit

Wire feed speed control and custom molded knob

P/N 005-0695



Motor

Motor assembly with leads and gear

P/N 211-0077



Micro Switch

Replacement trigger switch and bracket

P/N 005-0701



Barrel Insulation Kit

Kit includes custom molded barrel insulator, EZ-Lock[®] retainer, and insulator ring

P/N 005-0696



Gun Door

Custom molded door for drive and idler roll compartment

P/N 437-0253



Barrel Liners

Custom molded liners for barrel

.040" - 1/16"
(1.0mm - 1.6mm)

P/N 931-0145

BULK
P/N 615-0186



* Sold in packs of 5

Handle Kit

Kit includes right and left handle, door, and necessary hardware

P/N 005-0699



Snake Skin Cover

Heat resistant lead cover

15' - 50'

15' P/N 931-0110

25' P/N 931-0122

35' P/N 931-0132

50' P/N 931-0123



O-Ring Kit

All O-Rings necessary to maintain integrity of seals throughout entire gun

P/N 005-0806



* Bulk orders for individual O-Rings available upon request

Conduit Assembly

Custom Liner for Cobramatic Wire Feeders

15' - 50'

15' P/N 615-0601-15

25' P/N 615-0601-25

35' P/N 615-0601-35

50' P/N 615-0601-50



OEM Conduit Assembly

Custom Liner for Lincoln, Miller, and Fronius Wire Feeders

15'-50'

15' P/N 615-0620-15

25' P/N 615-0620-25

35' P/N 615-0620-35

50' P/N 615-0620-50



Aluminum Push-Pull Welding?

... yeah, we invented that.





PYTHON^{LX}

Air Cooled

The Python[®] LX merges the robust engineering of the Python[®] with the practical design of the Cobra MX. Applying the best features for each of these guns, the Python[®] LX promises to be a favorite in your arsenal. Rear trigger operation with integrated gas valve insures precise control of shielding gas. For those hard to reach welds, the Python[®] LX utilizes the EZ-Lock[®] 360° rotatable barrel. This cutting-edge gun promises to deliver years of reliability and will never disappoint.

Python[®] LX

Duty Cycle 100%



Key Features:

- EZ-Lock[®] barrel with 360° rotation. See pg. 79 for more options
- Flex Barrel compatible. See pg. 80
- Rear trigger operation
- Integrated mechanical gas valve
- Right or left hand wire feed adjustment protected in the handle
- CNC billet componentry
- Ultra-Flex power cable
- Balanced design provides hours of continuous wire feed without welder fatigue
- Ergonomic handle
- Full range of models available in 15', 25', 35' and 50' leads
- For aluminum, steel, stainless steel, flux core wires

Gas Valve Removal Tool



Gas Valve Removal Tool
(P/N 931-0105)



Modified Gas Valve
(P/N 431-1080)



Need to change your gas valve to a modified gas valve? Use the gas valve removal tool. The gas valve removal tool has been designed to easily remove your guns gas valve.

The modified gas valve is required for set ups in which gas flow is controlled by the wire feeder unit rather than the gun.

Specs:

- **Wire Size:**
 - .030" - 1/16" (0.8 mm - 1.6 mm) Aluminum Wire
 - .030" - .045" (0.8 mm - 1.2 mm) Steel, Stainless Steel, Flux Core, etc...
- **Wire Speed:**
 - 0-800 IPM (Optional 1000 IPM available *P/N 211-0080*)
- **Duty Cycle - 100%**
 - 225 AMPS - Air Cooled
 - All ratings using Argon Gas
- **Connections:**
 - MK Products[®] 7 Pin, Lincoln 7 Pin, Miller 10 Pin, Fronius 9 Pin

Python[®] LX Air Cooled

Compatible OEM Connections - All compatible guns use genuine MK Product consumables. Choose one of our Plug and Play direct connections below



MK Products [®] Compatibility	
Length	Model Number
15 ft	260-815
25 ft	260-825
35 ft	260-835
50 ft	260-850



Lincoln [®] , 7 Pin Compatibility	
Length	Model Number
15 ft	270-815
25 ft	270-825
35 ft	270-835
50 ft	270-850

12 Pin Lincoln connection use adapter (P/N 843-0679)



Miller [®] , 10 Pin Compatibility	
Length	Model Number
15 ft	272-815
25 ft	272-825
35 ft	272-835
50 ft	272-850



Fronius [®] , 9 Pin Compatibility	
Length	Model Number
15 ft	274-815
25 ft	274-825
35 ft	274-835
50 ft	274-850

Python[®] LX Air Cooled

Gun Assembly Components - The following items are equipped on all Python[®] LX Air Cooled Models



225 AMP 60° Curved EZ-Lock [®] Barrel	
Part Number	Model Number
	003-2147



Idler Roll Kit	
Part Number	Model Number
	005-0686

Kit includes idler roll, lock washer and screw for .030" - 1/16" wires



#10 Gas Cup - 5/8" ID	
Part Number	Model Number
	621-0250



Knurled Drive Roll	
Part Number	Model Number
	511-0101

.030" - 1/16" all wires



3/8" Spray Arc Contact Tip - .060 ID	
Part Number	Model Number
	621-0393-25

*Sold in packs of 25



Barrel Liner	
Part Number	Model Number
	931-0145

*Sold in packs of 5
.040" - 1/16" (1.0mm - 1.6mm)

See page 76-83 for additional Accessories and Consumables

 **Python[®] LX Air Cooled**
Gun Lead Assembly Components

MK Products [®] Compatibility					
Length	Power Cable Air Cooled	Control Cable	Gas Hose	Conduit Assembly	Snake Skin (cable cover)
15 ft	843-0630-15	005-0690	552-0242-15	615-0601-15	931-0110
25 ft	843-0630-25	005-0691	552-0242-25	615-0601-25	931-0122
35 ft	843-0630-35	005-0740	552-0242-35	615-0601-35	931-0132
50 ft	843-0630-50	005-0692	552-0242-50	615-0601-50	931-0123

Lincoln [®] , 7 Pin Compatibility					
Length	Power Cable Air Cooled	Control Cable	Gas Hose	Conduit Assembly	Snake Skin (cable cover)
15 ft	843-0640-15	005-0690	552-0241-15	615-0620-15	931-0110
25 ft	843-0640-25	005-0691	552-0241-25	615-0620-25	931-0122
35 ft	843-0640-35	005-0740	552-0241-35	615-0620-35	931-0132
50 ft	843-0640-50	005-0692	552-0241-50	615-0620-50	931-0123

Miller [®] , 10 Pin Compatibility					
Length	Power Cable Air Cooled	Control Cable	Gas Hose	Conduit Assembly	Snake Skin (cable cover)
15 ft	843-0640-15	005-0380-15	552-0241-15	615-0620-15	931-0110
25 ft	843-0640-25	005-0380-25	552-0241-25	615-0620-25	931-0122
35 ft	843-0640-35	005-0380-35	552-0241-35	615-0620-35	931-0132
50 ft	843-0640-50	005-0380-50	552-0241-50	615-0620-50	931-0123

Fronius [®] , 9 Pin Compatibility					
Length	Power Cable Air Cooled	Control Cable	Gas Hose	Conduit Assembly	Snake Skin (cable cover)
15 ft	843-0640-15	005-0381-15	552-0241-15	615-0620-15	931-0110
25 ft	843-0640-25	005-0381-25	552-0241-25	615-0620-25	931-0122
35 ft	843-0640-35	005-0381-35	552-0241-35	615-0620-35	931-0132
50 ft	843-0640-50	005-0381-50	552-0241-50	615-0620-50	931-0123

For Hard Wire Welding Accessories
(Steel, Stainless Steel, Flux Core, etc...) See pg. 83

225 AMP EZ-Lock[®] Air Cooled Barrels

225 AMP barrels come with #10 gas cup (P/N 621-0250), barrel liner (P/N 931-0145) and contact tip (P/N 621-0393-25)
See barrel images on page 79

Straight Air Cooled Barrel



Straight Air Cooled Barrel	
Part Number	Length
003-2151	6 Inch
003-2156	12 inch
003-2157	18 Inch

45° Air Cooled Barrel



45° Air Cooled Barrel	
Part Number	Length
003-2152	6 Inch
003-2158	12 inch
003-2159	18 Inch

60° Air Cooled Barrel



60° Air Cooled Barrel	
Part Number	Length
003-2147	6 Inch

225 AMP EZ-Lock[®] Air Cooled Barrel - Options

Tips, Cups, Insulators, and Adapters



Clip

P/N 313-0133

**Optional tip extender extends the reach of the barrel and helps protect original barrel threads*

Cup Insulator P/N 431-1774	Tip Extender P/N 621-0424 <i>*Optional</i>	Contact Tip Part Numbers on pg. 76	Gas Cup #6 P/N 621-0248 #8 P/N 621-0249 #10 P/N 621-0250 #10HD P/N 621-0251 #12HD P/N 621-0252

Spot Cup Option			
Gas Cup Adapter P/N 003-2667	Contact Tip Part Numbers on pg. 76	Inside Corner P/N 621-0174	Retaining Nut P/N 449-0193
		Outside Corner P/N 621-0175	
		Flat P/N 621-0176	

PYTHON[®]LX

Water Cooled

Turn up the heat and increase your duty cycle with the Python[®] LX water cooled gun. The Python[®] LX merges the robust engineering of the Python[®] with the practical design of the Cobra MX. Applying the best features for each of these guns, the Python[®] LX promises to be a favorite in your arsenal. Rear trigger operation with integrated gas valve insures precise control of shielding gas. For those hard to reach welds, the Python[®] LX utilizes the EZ-Lock[®] 360° rotatable barrel. This cutting-edge gun promises to deliver years of reliability and will never disappoint.

Python[®] LX

Duty Cycle 100%



Key Features:

- EZ-Lock[®] barrel with 360° rotation. See pg. 79 for more options
- Rear trigger operation
- Integrated mechanical gas valve
- Right or left hand wire feed adjustment protected in the handle
- CNC billet componentry
- Fingertip wire feed adjustment protected in the handle
- Ultra-Flex power cable
- Balanced design provides hours of continuous wire feed without welder fatigue
- Ergonomic handle
- Full range of models available in 15', 25', 35' and 50' leads
- For aluminum, steel, stainless steel, flux core wires

Specs:

- **Wire Size:**
 - .030" - 1/16" (0.8 mm - 1.6 mm) Aluminum Wire
 - .030" - .045" (0.8 mm - 1.2 mm) Steel, Stainless Steel, Flux Core, etc...
- **Wire Speed:**
 - 0-800 IPM (Optional 1000 IPM available P/N 211-0080)
- **Duty Cycle - 100%**
 - 400 AMPS - Water Cooled
 - All ratings using Argon Gas
- **Connections:**
 - MK Products[®] 7 Pin, Lincoln 7 Pin, Miller 10 Pin, Fronius 9 Pin

For BEST performance, use our Cobra[®] Coolant!

Failure to use Cobra[®] Coolant may void warranty

1 Gallon (3.78L)

Part Number 931-0060

1 Case (4Gal / 1Gal ea.)

Part Number 931-0060-4

5 Gallon (18.9L)

Part Number 931-0060-5GAL



Python[®] LX **Water Cooled**

Compatible OEM Connections - All compatible guns use genuine MK Product consumables. Choose one of our Plug and Play direct connections below



MK Products [®] Compatibility	
Length	Model Number
15 ft	261-815
25 ft	261-825
35 ft	261-835
50 ft	261-850



Lincoln [®] , 7 Pin Compatibility	
Length	Model Number
15 ft	271-815
25 ft	271-825
35 ft	271-835
50 ft	271-850

12 Pin Lincoln connection use adapter (P/N 843-0679)



Miller [®] , 10 Pin Compatibility	
Length	Model Number
15 ft	273-815
25 ft	273-825
35 ft	273-835
50 ft	273-850



Fronius [®] , 9 Pin Compatibility	
Length	Model Number
15 ft	275-815
25 ft	275-825
35 ft	275-835
50 ft	275-850

Python[®] LX **Water Cooled**

Gun Assembly Components - The following items are equipped on all Python[®] LX Water Cooled Models



400 AMP 60° Curved EZ-Lock [®] Barrel	
Part Number	003-2317



Idler Roll Kit	
Part Number	005-0686

Kit includes idler roll, lock washer and screw for .030" - 1/16" wires



#10 Gas Cup - 5/8" ID	
Part Number	621-0065



Knurled Drive Roll	
Part Number	511-0101

.030" - 1/16" all wires



3/8" Spray Arc Contact Tip - .060 ID	
Part Number	621-0393-25

*Sold in packs of 25



Barrel Liner	
Part Number	931-0145

*Sold in packs of 5
.040" - 1/16" (1.0mm - 1.6mm)

See page 76-83 for additional Accessories and Consumables

Python[®] LX Water Cooled Gun Lead Assembly Components

MK Products [®] Compatibility						
Length	Power Cable Water Cooled	Water Hose Return (BLUE)	Control Cable	Gas Hose	Conduit Assembly	Snake Skin (cable cover)
15 ft	005-0387-15	552-0243-15	005-0690	552-0242-15	615-0601-15	931-0110
25 ft	005-0387-25	552-0243-25	005-0691	552-0242-25	615-0601-25	931-0122
35 ft	005-0387-35	552-0243-35	005-0740	552-0242-35	615-0601-35	931-0132
50 ft	005-0387-50	552-0243-50	005-0692	552-0242-50	615-0601-50	931-0123

Lincoln [®] , 7 Pin Compatibility							
Length	Power Cable Water Cooled	Water Hose Return (BLUE)	Water Hose Return (RED)	Control Cable	Gas Hose	Conduit Assembly	Snake Skin (cable cover)
15 ft	005-0388-15	552-0239-15	552-0209	005-0690	552-0241-15	615-0620-15	931-0110
25 ft	005-0388-25	552-0239-25		005-0691	552-0241-25	615-0620-25	931-0122
35 ft	005-0388-35	552-0239-35		005-0740	552-0241-35	615-0620-35	931-0132
50 ft	005-0388-50	552-0239-50		005-0692	552-0241-50	615-0620-50	931-0123

Miller [®] , 10 Pin Compatibility							
Length	Power Cable Water Cooled	Water Hose Return (BLUE)	Water Hose Return (RED)	Control Cable	Gas Hose	Conduit Assembly	Snake Skin (cable cover)
15 ft	005-0388-15	552-0239-15	552-0209	005-0380-15	552-0241-15	615-0620-15	931-0110
25 ft	005-0388-25	552-0239-25		005-0380-25	552-0241-25	615-0620-25	931-0122
35 ft	005-0388-35	552-0239-35		005-0380-35	552-0241-35	615-0620-35	931-0132
50 ft	005-0388-50	552-0239-50		005-0380-50	552-0241-50	615-0620-50	931-0123

Fronius [®] , 9 Pin Compatibility							
Length	Power Cable Water Cooled	Water Hose Return (BLUE)	Water Hose Return (RED)	Control Cable	Gas Hose	Conduit Assembly	Snake Skin (cable cover)
15 ft	005-0388-15	552-0238-15	552-0211	005-0381-15	552-0241-15	615-0620-15	931-0110
25 ft	005-0388-25	552-0238-25		005-0381-25	552-0241-25	615-0620-25	931-0122
35 ft	005-0388-35	552-0238-35		005-0381-35	552-0241-35	615-0620-35	931-0132
50 ft	005-0388-50	552-0238-50		005-0381-50	552-0241-50	615-0620-50	931-0123

**For Hard Wire Welding Accessories
(Steel, Stainless Steel, Flux Core, etc...) See pg. 83**

400 AMP EZ-Lock[®] Water Cooled Barrels

400 AMP barrels come with #10 full water cooled cup (P/N 621-0065), barrel liner (P/N 931-0145) and contact tip (P/N 621-0393-25)
See barrel images on page 79

Straight Water Cooled Barrel



Straight W\C Barrel	
Part Number	Length
003-2315	6 Inch
003-2318	12 inch
003-2320	18 Inch

45° Water Cooled Barrel



45° Water Cooled Barrel	
Part Number	Length
003-2316	6 Inch
003-2319	12 inch
003-2321	18 Inch

60° Water Cooled Barrel



60° Water Cooled Barrel	
Part Number	Length
003-2317	6 Inch

Water Cooled Barrels Options

Tips, Cups, Insulators, and Adapters

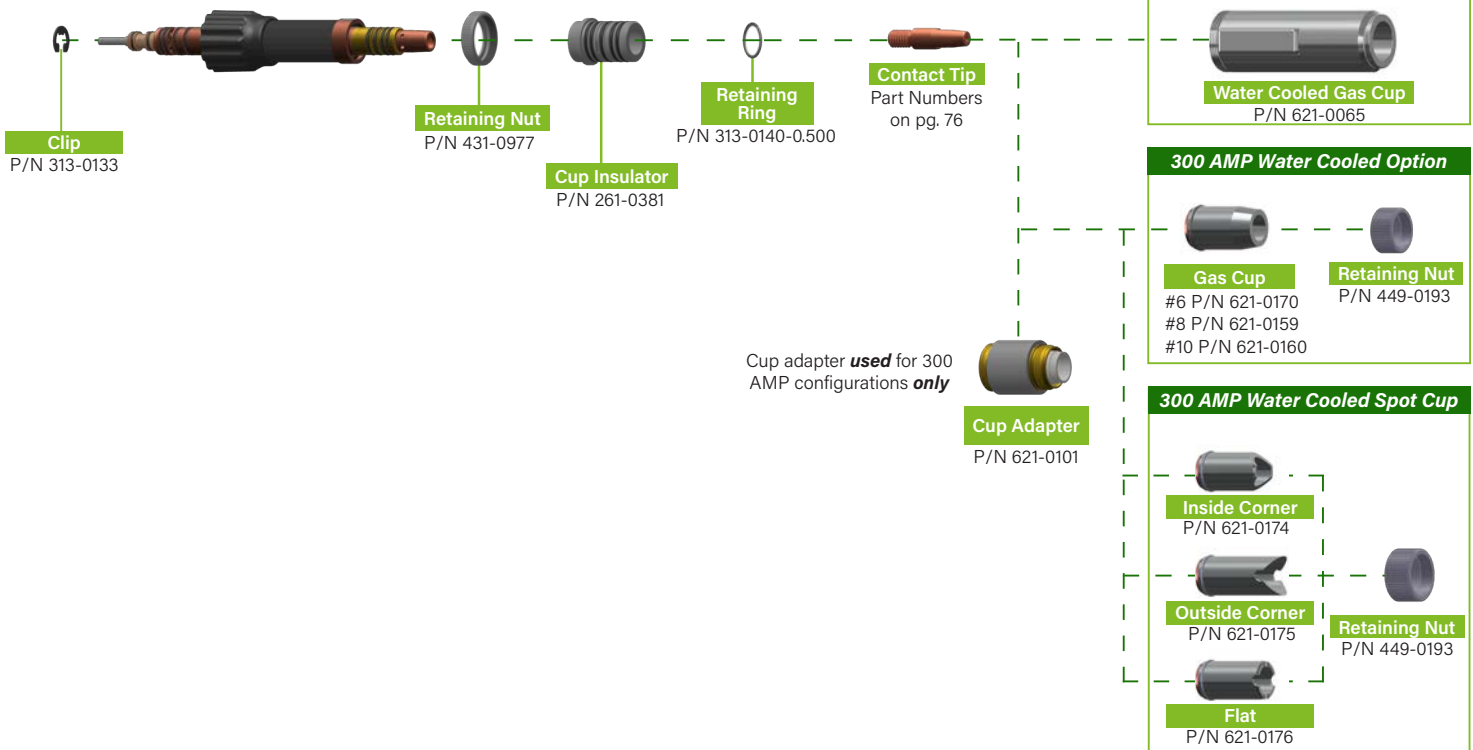

Python[®] LX Air & Water Spare Parts

Maintain optimum gun performance with genuine MK Products[®] parts. See pages 76-83 for additional Accessories and Consumables. For Hard Wire Accessories (Steel, Stainless Steel, Flux Core, etc..) See pg. 83

Trigger Kit

Kit includes custom molded trigger, spring, and dowel pin

P/N 005-0726



Potentiometer Assy

Wire feed speed control and custom molded knob

P/N 003-2190



Motor

Motor assembly with leads and gear

P/N 211-0077



Micro Switch

Replacement trigger switch and bracket

P/N 003-2274



Barrel Insulation Kit

Kit includes custom molded barrel insulator, EZ-Lock[®] retainer, and insulator ring

P/N 005-0696



Gun Door

Custom molded door for drive and idler roll compartment

P/N 437-0253



Barrel Liners

Custom molded liners for barrel

.040" - 1/16"
(1.0mm - 1.6mm)

P/N 931-0145

BULK
P/N 615-0186



* Sold in packs of 5

Handle Kit

Kit includes right and left handle, door, and necessary hardware

P/N 005-0750-GREEN



Snake Skin Cover

Heat resistant lead cover

15' - 50'

15' P/N 931-0110

25' P/N 931-0122

35' P/N 931-0132

50' P/N 931-0123



O-Ring Kit

All O-Rings necessary to maintain integrity of seals throughout entire gun

P/N 005-0806



* Bulk orders for individual O-Rings available upon request

Conduit Assembly

Custom Liner for Cobramatic Wire Feeders

15' - 50'

15' P/N 615-0601-15

25' P/N 615-0601-25

35' P/N 615-0601-35

50' P/N 615-0601-50



OEM Conduit Assembly

Custom Liner for Lincoln, Miller, and Fronius Wire Feeders

15'-50'

15' P/N 615-0620-15

25' P/N 615-0620-25

35' P/N 615-0620-35

50' P/N 615-0620-50





Quality Products Quality Services



16882 Armstrong Ave. Irvine, CA 92606 | www.mkproducts.com | 1800-787-9707



Cobra[®]MX

Air Cooled

Cobra[®] MX | Cobra[®] MX-HD

The Cobra[®] MX takes the original, time proven Cobra[®] gun and revamps it with all of our latest features and manufacturing techniques. With the famous gooseneck design and lightweight build, this push pull MIG gun continues to be a favorite for welders around the world. Two barrel options available, MX with 1/4" consumables and MX-HD with 3/8" consumables.

Cobra[®] MX
Duty Cycle 100%



Cobra[®] MX-HD
Duty Cycle 100%



Key Features:

- Cobra[®] fixed gooseneck design with high temp barrel insulator
- Rear trigger operation
- Integrated mechanical gas valve
- Right or left hand wire feed adjustment protected in the handle
- CNC billet componentry
- Ultra-Flex power cable
- Balanced design provides hours of continuous wire feed without welder fatigue
- Ergonomic handle
- Full range of models available in 15', 25', 35' and 50' leads
- For aluminum, steel, stainless steel, flux core wires

Gas Valve Removal Tool



Gas Valve Removal Tool
(P/N 931-0105)



Modified Gas Valve
(P/N 431-1080)



Need to change your gas valve to a modified gas valve? Use the gas valve removal tool. The gas valve removal tool has been designed to easily remove your guns gas valve.

The modified gas valve is required for set ups in which gas flow is controlled by the wire feeder unit rather than the gun.

Specs:

- **Wire Size:**
 - .030" - 1/16" (0.8 mm - 1.6 mm) Aluminum Wire
 - .030" - .045" (0.6 mm - 1.2 mm) Steel, Stainless Steel, Flux Core, etc...
- **Wire Speed:**
 - 0-800 IPM (Optional 1000 IPM available P/N 211-0080)
- **Duty Cycle - 100%:**
 - 175 AMPS - Air Cooled, **Cobra[®] MX**
 - 200 AMPS - Air Cooled, **Cobra[®] MX-HD**
 - All ratings using Argon Gas
- **Connections:**
 - MK Products[®] 7 Pin, Lincoln 7 Pin, Miller 10 Pin, Fronius 9 Pin

Cobra[®] MX **Air Cooled**

Compatible OEM Connections - All compatible guns use genuine MK Product consumables. Choose one of our Plug and Play direct connections below

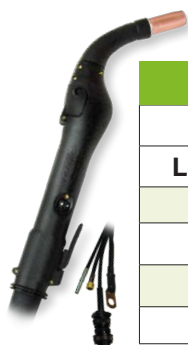

MK Products [®] Compatibility		
	Cobra [®] MX	Cobra [®] MX-HD
Length	Model Number	Model Number
15 ft	266-815	267-815
25 ft	266-825	267-825
35 ft	266-835	267-835
50 ft	266-850	267-850



Lincoln [®] , 7 Pin Compatibility		
	Cobra [®] MX	Cobra [®] MX-HD
Length	Model Number	Model Number
15 ft	276-815	277-815
25 ft	276-825	277-825
35 ft	276-835	277-835
50 ft	276-850	277-850

12 Pin Lincoln connection use adapter (P/N 843-0679)

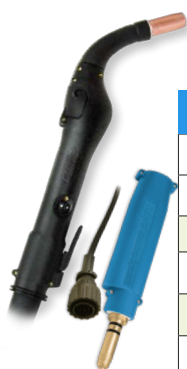

Miller [®] , 10 Pin Compatibility		
	Cobra [®] MX	Cobra [®] MX-HD
Length	Model Number	Model Number
15 ft	280-815	281-815
25 ft	280-825	281-825
35 ft	280-835	281-835
50 ft	280-850	281-850

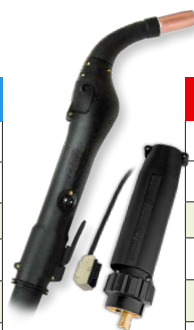

Fronius [®] , 9 Pin Compatibility		
	Cobra [®] MX	Cobra [®] MX-HD
Length	Model Number	Model Number
15 ft	284-815	285-815
25 ft	284-825	285-825
35 ft	284-835	285-835
50 ft	284-850	285-850

Cobra[®] MX **Air Cooled**

Gun Assembly Components - The following items are equipped on all Cobra[®] Air Cooled Models

Cobra[®] MX



Fixed A/W Barrel	
Part Number	003-2342



Gas Cup #8 Classic	
Part Number	001-0138-4

*Sold in packs of 4



Tip 1/4" X .060 ID Spray Arc	
Part Number	621-0003-25

*Sold in packs of 25

Cobra[®] MX-HD



Fixed A/W Barrel	
Part Number	003-2344



Gas Cup #8 HD	
Part Number	621-0421



Tip 3/8" X .060 ID HD Spray Arc	
Part Number	621-0393-25

*Sold in packs of 25

SHARED



Idler Roll Kit	
Part Number	005-0686

Kit includes idler roll, lock washer and screw for .030" - 1/16" wires



Knurled Drive Roll	
Part Number	511-0101

.030" - 1/16" all wires



Barrel Liner	
Part Number	931-0145

*Sold in packs of 5
.040" - 1/16" (1.0mm - 1.6mm)

See page 76-83 for additional Accessories and Consumables

 **Cobra[®] MX Air Cooled**
Gun Lead Assembly Components

MK Products [®] Compatibility					
Length	Power Cable Air Cooled	Control Cable	Gas Hose	Conduit Assembly	Snake Skin (cable cover)
15 ft	843-0630-15	005-0690	552-0242-15	615-0601-15	931-0110
25 ft	843-0630-25	005-0691	552-0242-25	615-0601-25	931-0122
35 ft	843-0630-35	005-0740	552-0242-35	615-0601-35	931-0132
50 ft	843-0630-50	005-0692	552-0242-50	615-0601-50	931-0123

Lincoln [®] , 7 Pin Compatibility					
Length	Power Cable Air Cooled	Control Cable	Gas Hose	Conduit Assembly	Snake Skin (cable cover)
15 ft	843-0640-15	005-0690	552-0241-15	615-0620-15	931-0110
25 ft	843-0640-25	005-0691	552-0241-25	615-0620-25	931-0122
35 ft	843-0640-35	005-0740	552-0241-35	615-0620-35	931-0132
50 ft	843-0640-50	005-0692	552-0241-50	615-0620-50	931-0123

Miller [®] , 10 Pin Compatibility					
Length	Power Cable Air Cooled	Control Cable	Gas Hose	Conduit Assembly	Snake Skin (cable cover)
15 ft	843-0640-15	005-0380-15	552-0241-15	615-0620-15	931-0110
25 ft	843-0640-25	005-0380-25	552-0241-25	615-0620-25	931-0122
35 ft	843-0640-35	005-0380-35	552-0241-35	615-0620-35	931-0132
50 ft	843-0640-50	005-0380-50	552-0241-50	615-0620-50	931-0123

Fronius [®] , 9 Pin Compatibility					
Length	Power Cable Air Cooled	Control Cable	Gas Hose	Conduit Assembly	Snake Skin (cable cover)
15 ft	843-0640-15	005-0381-15	552-0241-15	615-0620-15	931-0110
25 ft	843-0640-25	005-0381-25	552-0241-25	615-0620-25	931-0122
35 ft	843-0640-35	005-0381-35	552-0241-35	615-0620-35	931-0132
50 ft	843-0640-50	005-0381-50	552-0241-50	615-0620-50	931-0123



**For Hard Wire Welding Accessories
 (Steel, Stainless Steel, Flux Core, etc...) See pg. 83**

Cobra^{MX} - Barrel Options - 175 AMP Air Cooled



Tips, Cups, Insulators, and Adapters





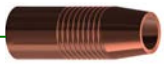

* Optional tip extender extends the reach of the barrel and helps protect original barrel threads

 Tip Extender P/N 621-0017 stackable up to 5 *Optional	 Contact Tip 1/4" Spray Arc Part Numbers on pg. 77	 Gas Cup #5 P/N 621-0079 #6 P/N 001-0137-4 #8 P/N 001-0138-4 #10 P/N 001-0139-4
--	--	--







Finned Cup, 3/8" Tip Adapter Option

 3/8" Tip Adapter P/N 431-1630	 Tip Extender P/N 621-0424	 Contact Tip 3/8" Spray Arc Part Numbers on pg. 76	 Finned Gas Cup #6 P/N 621-0248 #8 P/N 621-0249 #10 P/N 621-0250 #10HD P/N 621-0251 #12HD P/N 621-0252
--	--	---	--

Fixed Barrel HD Gas Cup, 3/8" Tip Adapter Option

 3/8" Tip Adapter P/N 003-2210	 Tip Extender P/N 621-0423 stackable up to 5 *Optional	 Contact Tip 3/8" Spray Arc Part Numbers on pg. 76	 HD Gas Cup #6 P/N 621-0420 #8 P/N 621-0421 #10 P/N 621-0422
--	--	---	--

Spot Cup Option



 Contact Tip 1/4" Part Numbers on pg. 77	 Spot Cup Adapter P/N 001-0545	 Inside Corner P/N 621-0197	 Outside Corner P/N 621-0199	 Retaining Nut P/N 449-0193
		 Flat P/N 621-0198		

Cobra^{MX-HD} Barrel Options - 200 AMP Air Cooled







Tips, Cups, Insulators, and Adapters



* Optional tip extender extends the reach of the barrel and helps protect original barrel threads

 Tip Extender P/N 621-0423 stackable up to 5 *Optional	 Contact Tip 3/8" Spray Arc Part Numbers on pg. 76	 HD Gas Cup #6 P/N 621-0420 #8 P/N 621-0421 #10 P/N 621-0422
--	---	--

Spot Cup Option

 Contact Tip 3/8" Spray Arc Part Numbers on pg. 76	 Gas Cup Adapter P/N 003-2665	 Inside Corner P/N 621-0197	 Outside Corner P/N 621-0199	 Retaining Nut P/N 449-0193
		 Flat P/N 621-0198		

Cobra[®]MX

Water Cooled

Cobra[®] MX | Cobra[®] MX-HD

The Water Cooled Cobra[®] MX takes our original, time proven Cobra gun and revamps it with all of our latest features and manufacturing techniques. With the famous gooseneck design and lightweight build, this push-pull MIG gun continues to be a favorite for welders around the world. Select the Water-cooled version for production applications up to 250 amps. Two barrels available, MX with 1/4" consumables and MX-HD with 3/8" consumables.



Cobra[®] MX
Duty Cycle 100%



Cobra[®] MX-HD
Duty Cycle 100%



Key Features:

- Cobra[®] fixed gooseneck design with high temp barrel insulator
- Rear trigger operation
- Integrated mechanical gas valve
- Right or left hand wire feed adjustment protected in the handle
- CNC billet componentry
- Ultra-Flex power cable
- Balanced design provides hours of continuous wire feed without welder fatigue
- Ergonomic handle
- Full range of models available in 15', 25', 35' and 50' leads
- For aluminum, steel, stainless steel, flux core wires

Specs:

- **Wire Size:**
 - .030" - 1/16" (0.8 mm - 1.6 mm) Aluminum Wire
 - .030" - .045" (0.8 mm - 1.2 mm) Steel, Stainless Steel, Flux Core, etc...
- **Wire Speed:**
 - 0-800 IPM (Optional 1000 IPM available P/N 211-0080)
- **Duty Cycle - 100%:**
 - 225 AMPS - Water Cooled, **Cobra[®] MX**
 - 250 AMPS - Water Cooled, **Cobra[®] MX-HD**
 - All ratings using Argon Gas
- **Connections:**
 - MK Products[®] 7 Pin, Lincoln 7 Pin, Miller 10 Pin, Fronius 9 Pin

For BEST performance, use our Cobra[®] Coolant!

Failure to use Cobra[®] Coolant may void warranty



1 Gallon (3.78L)	
Part Number	931-0060

1 Case (4Gal / 1Gal ea.)	
Part Number	931-0060-4

5 Gallon (18.9L)	
Part Number	931-0060-5GAL

Cobra^{MX} Water Cooled

Compatible OEM Connections - All compatible guns use genuine MK Product consumables. Choose one of our Plug and Play direct connections below

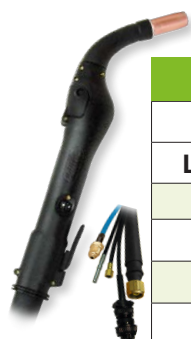

MK Products [®] Compatibility		
	Cobra [®] MX	Cobra [®] MX-HD
Length	Model Number	Model Number
15 ft	262-815	263-815
25 ft	262-825	263-825
35 ft	262-835	263-835
50 ft	262-850	263-850



Lincoln [®] , 7 Pin Compatibility		
	Cobra [®] MX	Cobra [®] MX-HD
Length	Model Number	Model Number
15 ft	278-815	279-815
25 ft	278-825	279-825
35 ft	278-835	279-835
50 ft	278-850	279-850

12 Pin Lincoln connection use adapter (P/N 843-0679)



Miller [®] , 10 Pin Compatibility		
	Cobra [®] MX	Cobra [®] MX-HD
Length	Model Number	Model Number
15 ft	282-815	283-815
25 ft	282-825	283-825
35 ft	282-835	283-835
50 ft	282-850	283-850



Fronius [®] , 9 Pin Compatibility		
	Cobra [®] MX	Cobra [®] MX-HD
Length	Model Number	Model Number
15 ft	286-815	287-815
25 ft	286-825	287-825
35 ft	286-835	287-835
50 ft	286-850	287-850

Cobra^{MX} Water Cooled

Gun Assembly Components - The following items are equipped on all Cobra^{MX} Water Cooled Models

Cobra^{MX}



Fixed A/W Barrel	
Part Number	003-2342



Gas Cup #8 Classic	
Part Number	001-0138-4

*Sold in packs of 4



Tip 1/4" X .060 ID Spray Arc	
Part Number	621-0003-25*

*Sold in packs of 25

Cobra^{MX}-HD



Fixed A/W Barrel	
Part Number	003-2344



Gas Cup #8 HD	
Part Number	621-0421



Tip 3/8" X .060 ID HD Spray Arc	
Part Number	621-0393-25*

*Sold in packs of 25

SHARED



Idler Roll Kit	
Part Number	005-0686

Kit includes idler roll, lock washer and screw for .030" - 1/16" wires



Knurled Drive Roll	
Part Number	511-0101

.030" - 1/16" all wires



Barrel Liner - 5 Pack	
Part Number	931-0145

*Sold in packs of 5
.040" - 1/16" (1.0mm - 1.6mm)

See page 76-83 for additional Accessories and Consumables

Cobra^{MX} Water Cooled Gun Lead Assembly Components

MK Products [®] Compatibility						
Length	Power Cable Water Cooled	Water Hose Return (BLUE)	Control Cable	Gas Hose	Conduit Assembly	Snake Skin (cable cover)
15 ft	005-0387-15	552-0243-15	005-0690	552-0242-15	615-0601-15	931-0110
25 ft	005-0387-25	552-0243-25	005-0691	552-0242-25	615-0601-25	931-0122
35 ft	005-0387-35	552-0243-35	005-0740	552-0242-35	615-0601-35	931-0132
50 ft	005-0387-50	552-0243-50	005-0692	552-0242-50	615-0601-50	931-0123

Lincoln [®] , 7 Pin Compatibility							
Length	Power Cable Water Cooled	Water Hose Return (BLUE)	Water Hose Return (RED)	Control Cable	Gas Hose	Conduit Assembly	Snake Skin (cable cover)
15 ft	005-0388-15	552-0239-15	552-0209	005-0690	552-0241-15	615-0620-15	931-0110
25 ft	005-0388-25	552-0239-25		005-0691	552-0241-25	615-0620-25	931-0122
35 ft	005-0388-35	552-0239-35		005-0740	552-0241-35	615-0620-35	931-0132
50 ft	005-0388-50	552-0239-50		005-0692	552-0241-50	615-0620-50	931-0123

Miller [®] , 10 Pin Compatibility							
Length	Power Cable Water Cooled	Water Hose Return (BLUE)	Water Hose Return (RED)	Control Cable	Gas Hose	Conduit Assembly	Snake Skin (cable cover)
15 ft	005-0388-15	552-0239-15	552-0209	005-0380-15	552-0241-15	615-0620-15	931-0110
25 ft	005-0388-25	552-0239-25		005-0380-25	552-0241-25	615-0620-25	931-0122
35 ft	005-0388-35	552-0239-35		005-0380-35	552-0241-35	615-0620-35	931-0132
50 ft	005-0388-50	552-0239-50		005-0380-50	552-0241-50	615-0620-50	931-0123

Fronius [®] , 9 Pin Compatibility							
Length	Power Cable Water Cooled	Water Hose Return (BLUE)	Water Hose Return (RED)	Control Cable	Gas Hose	Conduit Assembly	Snake Skin (cable cover)
15 ft	005-0388-15	552-0238-15	552-0211	005-0381-15	552-0241-15	615-0620-15	931-0110
25 ft	005-0388-25	552-0238-25		005-0381-25	552-0241-25	615-0620-25	931-0122
35 ft	005-0388-35	552-0238-35		005-0381-35	552-0241-35	615-0620-35	931-0132
50 ft	005-0388-50	552-0238-50		005-0381-50	552-0241-50	615-0620-50	931-0123

**For Hard Wire Welding Accessories
(Steel, Stainless Steel, Flux Core, etc...) See pg. 83**

Cobra^{MX} - Barrel Options - 225 AMP Water

Tips, Cups, Insulators, and Adapters



* Optional tip extender extends the reach of the barrel and helps protect original barrel threads

<p>Tip Extender P/N 621-0017 stackable up to 5 *Optional</p>	<p>Contact Tip 1/4" Spray Arc Part Numbers on pg. 77</p>	<p>Gas Cup #5 P/N 621-0079 #6 P/N 001-0137-4 #8 P/N 001-0138-4 #10 P/N 001-0139-4</p>
--	---	--

Finned Cup, 3/8" Tip Adapter Option

<p>3/8" Tip Adapter P/N 431-1630</p>	<p>Tip Extender P/N 621-0424</p>	<p>Contact Tip 3/8" Spray Arc Part Numbers on pg. 76</p>	<p>Finned Gas Cup #6 P/N 621-0248 #8 P/N 621-0249 #10 P/N 621-0250 #10HD P/N 621-0251 #12HD P/N 621-0252</p>
---	---	---	---

Fixed Barrel HD Gas Cup, 3/8" Tip Adapter Option

<p>3/8" Tip Adapter P/N 003-2210</p>	<p>Tip Extender P/N 621-0423 stackable up to 5 *Optional</p>	<p>Contact Tip 3/8" Spray Arc Part Numbers on pg. 76</p>	<p>HD Gas Cup #6 P/N 621-0420 #8 P/N 621-0421 #10 P/N 621-0422</p>
---	--	---	---

Spot Cup Option

<p>Contact Tip 1/4" Part Numbers on pg. 77</p>	<p>Spot Cup Adapter P/N 001-0545</p>	<p>Inside Corner P/N 621-0197</p>	<p>Outside Corner P/N 621-0199</p>	<p>Retaining Nut P/N 449-0193</p>
		<p>Flat P/N 621-0198</p>		

Cobra^{MX-HD} Barrel Options - 250 AMP Water Cooled

Tips, Cups, Insulators, and Adapters



* Optional tip extender extends the reach of the barrel and helps protect original barrel threads

<p>Tip Extender P/N 621-0423 stackable up to 5 *Optional</p>	<p>Contact Tip 3/8" Spray Arc Part Numbers on pg. 76</p>	<p>HD Gas Cup #6 P/N 621-0420 #8 P/N 621-0421 #10 P/N 621-0422</p>
--	---	---

Spot Cup Option

<p>Contact Tip 3/8" Spray Arc Part Numbers on pg. 76</p>	<p>Gas Cup Adapter P/N 003-2665</p>	<p>Inside Corner P/N 621-0197</p>	<p>Outside Corner P/N 621-0199</p>	<p>Retaining Nut P/N 449-0193</p>
		<p>Flat P/N 621-0198</p>		

Cobra^{MX} & MX-HD Air & Water Spare Parts

Maintain optimum gun performance with genuine MK Products[®] parts. See pages 76-83 for additional Accessories and Consumables. For Hard Wire Accessories (Steel, Stainless Steel, Flux Core, etc..) See pg. 83

Trigger Kit

Kit includes custom molded trigger, spring, and dowel pin

P/N 005-0726



Potentiometer Assy

Wire feed speed control and custom molded knob

P/N 003-2190



Motor

Motor assembly with leads and gear

P/N 211-0085



Micro Switch

Replacement trigger switch and bracket

P/N 003-2274



Barrel Insulation

Custom molded barrel insulation

P/N 437-0299



Gun Door

Custom molded door for drive and idler roll compartment

P/N 437-0253



Barrel Liners

Custom molded liners for barrel

.040" - 1/16"
(1.0mm - 1.6mm)

P/N 931-0145

BULK
P/N 615-0186



* Sold in packs of 5

Handle Kit

Kit includes right and left handle, door, and necessary hardware

P/N 005-0725



Snake Skin Cover

Heat resistant lead cover

15' - 50'

15' P/N 931-0110
25' P/N 931-0122
35' P/N 931-0132
50' P/N 931-0123



Fixed O-Ring Kit

All O-Rings necessary to maintain integrity of seals throughout entire gun

P/N 005-0807



* Bulk orders for individual O-Rings available upon request

Conduit Assembly

Custom Liner for Cobramatic Wire Feeders

15' - 50'

15' P/N 615-0601-15
25' P/N 615-0601-25
35' P/N 615-0601-35
50' P/N 615-0601-50



OEM Conduit Assembly

Custom Liner for Lincoln, Miller, and Fronius Wire Feeders

15'-50'

15' P/N 615-0620-15
25' P/N 615-0620-25
35' P/N 615-0620-35
50' P/N 615-0620-50



Dependable & Durable Systems

MIG
PUSH-PULL SYSTEMS

OrbitalTM



 **MK**
PRODUCTS
Cobra Welding Systems

PRINCE^{XL}

Air Cooled

Experience the highly innovative Prince[®] XL Push-Pull gun. MK Products[®] engineered this workhorse for the rigors of heavy industrial production where downtime is unacceptable. Recognized around the world as the most versatile pistol grip gun, the Prince[®] XL easily beats the competition with unmatched performance. Whether it be aluminum or steel, the Prince[®] XL is up to the challenge and remains ready to meet all of your needs. It really is the Prince[®] of push-pull.



Prince[®] XL
Duty Cycle 100%

225
A
M
P
S
A/C

Key Features:

- EZ-Lock[®] barrel with 360° degree rotation. See pg. 79 for more options
- Flex Barrel compatible. See pg. 80
- Ergonomic pistol grip handle
- Integrated mechanical gas valve
- Balanced design provides hours of continuous wire feed without welder fatigue
- Wire feed adjustment protected in bottom of handle
- CNC billet componentry
- Ultra-Flex power cable
- Full range of models available in 15', 25', 35' and 50' leads
- For aluminum, steel, stainless steel, flux core wires

Gas Valve Removal Tool



Gas Valve Removal Tool
(P/N 931-0105)



Modified Gas Valve
(P/N 431-1080)



Need to change your gas valve to a modified gas valve? Use the gas valve removal tool. The gas valve removal tool has been designed to easily remove your guns gas valve.

The modified gas valve is required for set ups in which gas flow is controlled by the wire feeder unit rather than the gun.

Specs:

- **Wire Size:**
 - .030" - 1/16" (0.8 mm - 1.6 mm) Aluminum Wire
 - .030" - .045" (0.8 mm - 1.2 mm) Steel, Stainless Steel, Flux Core, etc...
- **Wire Speed:**
 - 0-800 IPM
- **Duty Cycle - 100%**
 - 225 AMPS - Air Cooled
 - All ratings using Argon Gas
- **Connections:**
 - MK Products[®] 7 Pin, Lincoln 7 Pin, Miller 10 Pin, Fronius 9 Pin

Prince[®] XL Air Cooled

Compatible OEM Connections - All compatible guns use genuine MK Product consumables. Choose one of our Plug and Play direct connections below

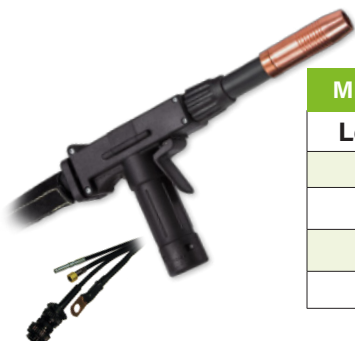

MK Products[®] Compatibility

Length	Model Number
15 ft	317-715
25 ft	317-725
35 ft	317-735
50 ft	317-750



Lincoln[®], 7 Pin Compatibility

Length	Model Number
15 ft	310-715
25 ft	310-725
35 ft	310-735
50 ft	310-750

12 Pin Lincoln connection use adapter (P/N 843-0679)



Miller[®], 10 Pin Compatibility

Length	Model Number
15 ft	332-715
25 ft	332-725
35 ft	332-735
50 ft	332-750



Fronius[®], 9 Pin Compatibility

Length	Model Number
15 ft	330-715
25 ft	330-725
35 ft	330-735
50 ft	330-750

Prince[®] XL Air Cooled

Gun Assembly Components - The following items are equipped on all Prince[®] XL Air Cooled Models



225 AMP Straight EZ-Lock[®] Barrel

Part Number	003-2151
-------------	----------



Idler Roll Kit

Part Number	005-0686
-------------	----------

Kit includes idler roll, lock washer and screw for .030" - 1/16" wires



#10 Gas Cup - 5/8" ID

Part Number	621-0250
-------------	----------



Knurled Drive Roll

Part Number	511-0101
-------------	----------

.030" - 1/16" all wires



3/8" Spray Arc Contact Tip - .060 ID

Part Number	621-0393-25
-------------	-------------

*Sold in packs of 25



Barrel Liner

Part Number	931-0145
-------------	----------

*Sold in packs of 5
.040" - 1/16" (1.0mm - 1.6mm)

See page 76-83 for additional Accessories and Consumables

 Prince[®] XL **Air Cooled**
Gun Lead Assembly Components

MK Products [®] Compatibility					
Length	Power Cable Air Cooled	Control Cable	Gas Hose	Conduit Assembly	Snake Skin (cable cover)
15 ft	843-0487	005-0268	552-0242-15	615-0601-15	931-0110
25 ft	843-0484	005-0269	552-0242-25	615-0601-25	931-0122
35 ft	843-0488	005-0307	552-0242-35	615-0601-35	931-0132
50 ft	843-0485	005-0272	552-0242-50	615-0601-50	931-0123

Lincoln [®] , 7 Pin Compatibility					
Length	Power Cable Air Cooled	Control Cable	Gas Hose	Conduit Assembly	Snake Skin (cable cover)
15 ft	843-0619	005-0268	552-0241-15	615-0620-15	931-0110
25 ft	843-0620	005-0269	552-0241-25	615-0620-25	931-0122
35 ft	843-0622	005-0307	552-0241-35	615-0620-35	931-0132
50 ft	843-0621	005-0272	552-0241-50	615-0620-50	931-0123

Miller [®] , 10 Pin Compatibility					
Length	Power Cable Air Cooled	Control Cable	Gas Hose	Conduit Assembly	Snake Skin (cable cover)
15 ft	843-0619	005-0405-15	552-0241-15	615-0620-15	931-0110
25 ft	843-0620	005-0405-25	552-0241-25	615-0620-25	931-0122
35 ft	843-0622	005-0405-35	552-0241-35	615-0620-35	931-0132
50 ft	843-0621	005-0405-50	552-0241-50	615-0620-50	931-0123

Fronius [®] , 9 Pin Compatibility					
Length	Power Cable Air Cooled	Control Cable	Gas Hose	Conduit Assembly	Snake Skin (cable cover)
15 ft	843-0619	005-0406-15	552-0241-15	615-0620-15	931-0110
25 ft	843-0620	005-0406-25	552-0241-25	615-0620-25	931-0122
35 ft	843-0622	005-0406-35	552-0241-35	615-0620-35	931-0132
50 ft	843-0621	005-0406-50	552-0241-50	615-0620-50	931-0123

**For Hard Wire Welding Accessories
(Steel, Stainless Steel, Flux Core, etc...) See pg. 83**

225 AMP EZ-Lock[®] Air Cooled Barrels

225 AMP barrels come with #10 gas cup (P/N 621-0250), barrel liner (P/N 931-0145) and contact tip (P/N 621-0393-25)
See barrel images on page 79

Straight Air Cooled Barrel



Straight Air Cooled Barrel	
Part Number	Length
003-2151	6 Inch
003-2156	12 inch
003-2157	18 Inch

45° Air Cooled Barrel



45° Air Cooled Barrel	
Part Number	Length
003-2152	6 Inch
003-2158	12 inch
003-2159	18 Inch

225 AMP EZ-Lock[®] Air Cooled Barrel - Options

Tips, Cups, Insulators, and Adapters



**Optional tip extender extends the reach of the barrel and helps protect original barrel threads*

 Cup Insulator P/N 431-1774	 Tip Extender P/N 621-0424 <i>*Optional</i>	 Contact Tip Part Numbers on pg. 76	 Gas Cup #6 P/N 621-0248 #8 P/N 621-0249 #10 P/N 621-0250 #10HD P/N 621-0251 #12HD P/N 621-0252
--	---	--	--

Spot Cup Option			
 Gas Cup Adapter P/N 003-2667	 Contact Tip Part Numbers on pg. 76	 Inside Corner P/N 621-0174	 Retaining Nut P/N 449-0193
		 Outside Corner P/N 621-0175	
		 Flat P/N 621-0176	

PRINCE^{XL}

Water Cooled

Experience the most powerful water cooled pistol grip gun on the market! MK Products® engineered this highly innovative workhorse for the rigors of heavy industrial production where high amperage settings are required. Recognized around the world as the most versatile pistol grip gun, the Prince® XL easily beats the competition with unmatched performance. Whether it be aluminum or steel, the Prince® XL is up to the challenge and remains ready to meet all of your needs. It really is the Prince of push-pull.



Prince® XL
Duty Cycle 100%



Key Features:

- EZ-Lock® barrel with 360° degree rotation. See pg. 79 for more options
- Ergonomic pistol grip handle
- Integrated mechanical gas valve
- Balanced design provides hours of continuous wire feed without welder fatigue
- Wire feed adjustment protected in bottom of handle
- CNC billet componentry
- Ultra-Flex power cable
- Full range of models available in 15', 25', 35' and 50' leads
- For aluminum, steel, stainless steel, flux core wires

Specs:

- **Wire Size:**
 - .030" - 1/16" (0.8 mm - 1.6 mm) Aluminum Wire
 - .030" - .045" (0.8 mm - 1.2 mm) Steel, stainless steel, flux core, etc...
- **Wire Speed:**
 - 0-800 IPM
- **Duty Cycle - 100%**
 - 400 AMPS - Water Cooled
 - All ratings using Argon Gas
- **Connections:**
 - MK Products® 7 Pin, Lincoln 7 Pin, Miller 10 Pin, Fronius 9 Pin

For BEST performance, use our Cobra® Coolant!

Failure to use Cobra® Coolant may void warranty



1 Gallon (3.78L)	
Part Number	931-0060

1 Case (4Gal / 1Gal ea.)	
Part Number	931-0060-4

5 Gallon (18.9L)	
Part Number	931-0060-5GAL

Prince[®] XL Water Cooled

Compatible OEM Connections - All compatible guns use genuine MK Product consumables. Choose one of our Plug and Play direct connections below



MK Products [®] Compatibility	
Length	Model Number
15 ft	318-715
25 ft	318-725
35 ft	318-735
50 ft	318-750



Lincoln [®] , 7 Pin Compatibility	
Length	Model Number
15 ft	311-715
25 ft	311-725
35 ft	311-735
50 ft	311-750

12 Pin Lincoln connection use adapter (P/N 843-0679)



Miller [®] , 10 Pin Compatibility	
Length	Model Number
15 ft	333-715
25 ft	333-725
35 ft	333-735
50 ft	333-750



Fronius [®] , 9 Pin Compatibility	
Length	Model Number
15 ft	331-715
25 ft	331-725
35 ft	331-735
50 ft	331-750

Prince[®] XL Water Cooled

Gun Assembly Components - The following items are equipped on all Prince[®] XL Water Cooled Models

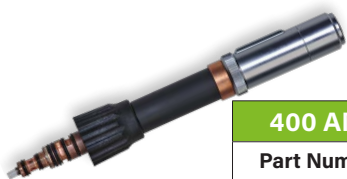

400 AMP Straight EZ-Lock [®] Barrel	
Part Number	003-2315



Idler Roll Kit	
Part Number	005-0686

Kit includes idler roll, lock washer and screw for .030" - 1/16" wires



#10 Gas Cup - 5/8" ID	
Part Number	621-0065



Knurled Drive Roll	
Part Number	511-0101

.030" - 1/16" all wires



3/8" Spray Arc Contact Tip - .060 ID	
Part Number	621-0393-25

*Sold in packs of 25



Barrel Liner	
Part Number	931-0145

*Sold in packs of 5
.040" - 1/16" (1.0mm - 1.6mm)

See page 76-83 for additional Accessories and Consumables

Prince[®] XL **Water Cooled**
Gun Lead Assembly Components

MK Products [®] Compatibility						
Length	Power Cable Water Cooled	Water Hose Return (BLUE)	Control Cable	Gas Hose	Conduit Assembly	Snake Skin (cable cover)
15 ft	005-0387-15	552-0243-15	005-0268	552-0242-15	615-0601-15	931-0110
25 ft	005-0387-25	552-0243-25	005-0269	552-0242-25	615-0601-25	931-0122
35 ft	005-0387-35	552-0243-35	005-0307	552-0242-35	615-0601-35	931-0132
50 ft	005-0387-50	552-0243-50	005-0272	552-0242-50	615-0601-50	931-0123

Lincoln [®] , 7 Pin Compatibility							
Length	Power Cable Water Cooled	Water Hose Return (BLUE)	Water Hose Return (RED)	Control Cable	Gas Hose	Conduit Assembly	Snake Skin (cable cover)
15 ft	005-0388-15	552-0239-15	552-0209	005-0268	552-0241-15	615-0620-15	931-0110
25 ft	005-0388-25	552-0239-25		005-0269	552-0241-25	615-0620-25	931-0122
35 ft	005-0388-35	552-0239-35		005-0307	552-0241-35	615-0620-35	931-0132
50 ft	005-0388-50	552-0239-50		005-0272	552-0241-50	615-0620-50	931-0123

Miller [®] , 10 Pin Compatibility							
Length	Power Cable Water Cooled	Water Hose Return (BLUE)	Water Hose Return (RED)	Control Cable	Gas Hose	Conduit Assembly	Snake Skin (cable cover)
15 ft	005-0388-15	552-0239-15	552-0209	005-0405-15	552-0241-15	615-0620-15	931-0110
25 ft	005-0388-25	552-0239-25		005-0405-25	552-0241-25	615-0620-25	931-0122
35 ft	005-0388-35	552-0239-35		005-0405-35	552-0241-35	615-0620-35	931-0132
50 ft	005-0388-50	552-0239-50		005-0405-50	552-0241-50	615-0620-50	931-0123

Fronius [®] , 9 Pin Compatibility							
Length	Power Cable Water Cooled	Water Hose Return (BLUE)	Water Hose Return (RED)	Control Cable	Gas Hose	Conduit Assembly	Snake Skin (cable cover)
15 ft	005-0388-15	552-0238-15	552-0211	005-0406-15	552-0241-15	615-0620-15	931-0110
25 ft	005-0388-25	552-0238-25		005-0406-25	552-0241-25	615-0620-25	931-0122
35 ft	005-0388-35	552-0238-35		005-0406-35	552-0241-35	615-0620-35	931-0132
50 ft	005-0388-50	552-0238-50		005-0406-50	552-0241-50	615-0620-50	931-0123

**For Hard Wire Welding Accessories
(Steel, Stainless Steel, Flux Core, etc...) See pg. 83**

400 AMP EZ-Lock[®] Water Cooled Barrels

400 AMP barrels come with #10 full water cooled cup (P/N 621-0065), barrel liner (P/N 931-0145) and contact tip (P/N 621-0393-25)
See barrel images on page 79

Straight Water Cooled Barrel



Straight W\C Barrel	
Part Number	Length
003-2315	6 Inch
003-2318	12 inch
003-2320	18 Inch

45° Water Cooled Barrel



45° Water Cooled Barrel	
Part Number	Length
003-2316	6 Inch
003-2319	12 inch
003-2321	18 Inch

Water Cooled Barrels Options

Tips, Cups, Insulators, and Adapters

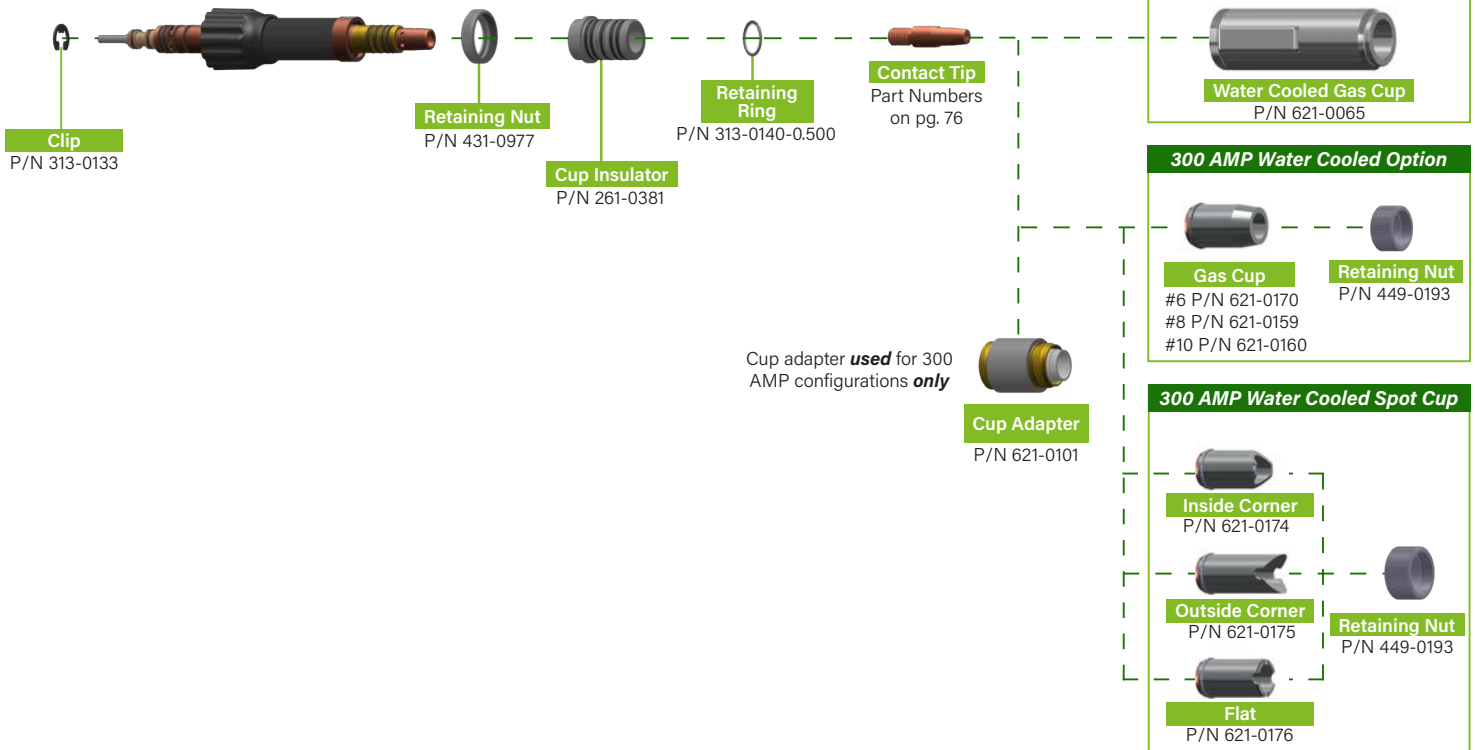

Prince[®] XL Air & Water Spare Parts

Maintain optimum gun performance with genuine MK Products[®] parts. See pages 76-83 for additional Accessories and Consumables. For Hard Wire Accessories (Steel, Stainless Steel, Flux Core, etc..) See pg. 83

Trigger Kit

Kit includes custom molded trigger, pin spring, and dowel pin

P/N 005-0550



Potentiometer Assy Kit

Kit includes wire feed speed control and custom molded knob

P/N 005-0661



Motor

Motor assembly with leads and gear

MK & Fronius compatible
P/N 211-0071

Lincoln & Miller compatible
P/N 211-0088



Micro Switch

Replacement trigger switch and bracket

P/N 003-0568



Barrel Insulation Kit

Kit includes custom molded barrel insulator, EZ-Lock[®] retainer, and insulator ring

P/N 005-0696

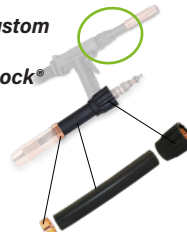

Gun Door

Custom molded door for drive and idler roll compartment

P/N 431-3117



Barrel Liners

Custom molded liners for barrel

.040" - 1/16"
(1.0mm - 1.6mm)

P/N 931-0145

BULK
P/N 615-0186



* Sold in packs of 5

Handle Kit

Kit includes right and left handle, door, and necessary hardware

P/N 005-0633



Snake Skin Cover

Heat resistant lead cover

15' - 50'

15' P/N 931-0110

25' P/N 931-0122

35' P/N 931-0132

50' P/N 931-0123



O-Ring Kit

Kit includes all O-Rings necessary to maintain integrity of seals throughout entire gun

P/N 005-0806



* Bulk orders for individual O-Rings available upon request

Conduit Assembly

Custom Liner for Cobramatic Wire Feeders

15' - 50'

15' P/N 615-0601-15

25' P/N 615-0601-25

35' P/N 615-0601-35

50' P/N 615-0601-50



OEM Conduit Assembly

Custom Liner for Lincoln, Miller, and Fronius Wire Feeders

15'-50'

15' P/N 615-0620-15

25' P/N 615-0620-25

35' P/N 615-0620-35

50' P/N 615-0620-50





Over 50 years of dedication.



16882 Armstrong Ave. Irvine, CA 92606 | www.mkproducts.com | 1800-787-9707

Prince[®] XL Spool Gun Air Cooled

The most powerful and versatile spool gun we have to offer. Robustly engineered for daily production, the Prince[®] XL Spool Gun promises to provide years of reliable service. Maintain the flow of your production line with quick change 1 lb. and 2 lb. wire spools. Select from several interchangeable EZ-Lock[®] barrels adapt to a variety of welding conditions.



Prince[®] XL Spool Gun

Duty Cycle 100%

225
A
M
P
S
A/C

Prince[®] XL Spool Gun

Model Number	Length
319-725	25 ft
319-750	50 ft

Key Features:

- Adaptable to most power supplies
- EZ-Lock[®] barrel with 360° degree rotation. See pg. 79 for more options
- Flex Barrel compatible. See pg. 80
- Ergonomic pistol grip handle
- Balanced design provides hours of continuous wire feed without welder fatigue
- Wire feed adjustment protected in bottom of handle
- CNC billet componentry
- Ultra-Flex power cable
- Converts easily to a push pull gun for use with 12" spool in Cobramatic[®] Cabinet
- 900 IPM
- Full range of models available in 25' and 50' leads
- For aluminum, steel, stainless steel, flux core wires

Specs:

- **Wire Size:**
 - .030" - 1/16" (0.8 mm - 1.6 mm) Aluminum Wire
 - .030" - .045" (0.8 mm - 1.2 mm) Steel, stainless steel, flux core, etc...
- **Wire Speed:**
 - 900 IPM
- **Spool Size:**
 - 1 lb. and 2 lb. Spools
- **Duty Cycle - 100%**
 - 225 AMPS - Air Cooled
 - All ratings using Argon Gas

Gas Valve Removal Tool



Gas Valve Removal Tool
(P/N 931-0105)



Modified Gas Valve
(P/N 431-1080)



Need to change your gas valve to a modified gas valve? Use the gas valve removal tool. The gas valve removal tool has been designed to easily remove your guns gas valve.

The modified gas valve is required for set ups in which gas flow is controlled by the wire feeder unit rather than the gun.

Prince® XL Spool Gun

Gun Assembly Components - The following items are equipped on all Prince® XL Spool Gun



225 AMP Straight EZ-Lock Barrel	
Part Number	003-2151



Idler Roll Kit	
Part Number	005-0686

Kit includes idler roll, lock washer and screw for .030" - 1/16" wires



#10 Gas Cup - 5/8" ID	
Part Number	621-0250



Knurled Drive Roll	
Part Number	511-0101

.030" - 1/16" all wires



3/8" Spray Arc Contact Tip - .060 ID	
Part Number	621-0393-25

**Sold in packs of 25*



Barrel Liner	
Part Number	931-0145

**Sold in packs of 5
.040" - 1/16" (1.0mm - 1.6mm)*

See page 76-83 for additional Accessories and Consumables

Prince® XL spool Gun

Gun Lead Assembly Components

Gun Lead Assembly Components				
Length	Power Cable Air Cooled	Control Cable	Gas Hose	Snake Skin (cable cover)
25 ft	843-0484	005-0269	552-0244-25	931-0122
50 ft	843-0485	005-0272	552-0244-50	931-0123

**For Hard Wire Welding Accessories
(Steel, Stainless Steel, Flux Core, etc...) See pg. 83**

225 AMP EZ-Lock® Air Cooled Barrels

225 AMP barrels come with #10 gas cup (P/N 621-0250), barrel liner (P/N 931-0145) and contact tip (P/N 621-0393-25)
See barrel images on page 79

Straight Air Cooled Barrel



Straight Air Cooled Barrel	
Part Number	Length
003-2151	6 Inch
003-2156	12 inch
003-2157	18 Inch

45° Air Cooled Barrel







45° Air Cooled Barrel	
Part Number	Length
003-2152	6 Inch
003-2158	12 inch
003-2159	18 Inch







225 AMP EZ-Lock® Air Cooled Barrel - Options

Tips, Cups, Insulators, and Adapters



**Optional tip extender extends the reach of the barrel and helps protect original barrel threads*

 Cup Insulator P/N 431-1774	 Tip Extender P/N 621-0424 <i>*Optional</i>	 Contact Tip Part Numbers on pg. 76	 Gas Cup #6 P/N 621-0248 #8 P/N 621-0249 #10 P/N 621-0250 #10HD P/N 621-0251 #12HD P/N 621-0252
---	--	---	---

Spot Cup Option			
 Gas Cup Adapter P/N 003-2667	 Contact Tip Part Numbers on pg. 76	 Inside Corner P/N 621-0174	 Retaining Nut P/N 449-0193
		 Outside Corner P/N 621-0175	
		 Flat P/N 621-0176	

Prince® XL Spool Gun Spare Parts

Maintain optimum gun performance with genuine MK Products® parts. See pages 76-83 for additional Accessories and Consumables. For Hard Wire Accessories (Steel, Stainless Steel, Flux Core, etc..) See pg. 83

Prince® XL Barrel Insulation Kit

Kit includes custom molded barrel insulator, EZ-Lock® retainer, and insulator ring

P/N 005-0696

Prince® XL Spool Gun Handle Kit

Kit includes right and left handle, door, and necessary hardware

P/N 005-0633

Prince® XL Motor

Motor assembly with leads and gear

P/N 211-0071

Micro Switch

Replacement trigger switch and bracket

P/N 003-0568

Trigger Kit

Kit includes custom molded trigger, pin spring, and dowel pin

P/N 005-0550

Potentiometer Assy Kit

Kit includes wire feed speed control and custom molded knob

P/N 005-0661

Barrel Liners

Custom molded liners for barrel

.040" - 1/16"
(1.0mm - 1.6mm)

P/N 931-0145

BULK
P/N 615-0186

O-Ring Kit

Kit includes all O-Rings necessary to maintain integrity of seals throughout entire gun

P/N 005-0805

Snake Skin Cover

Heat resistant lead cover

25' / 50'

25' P/N 931-0122
50' P/N 931-0123

* Sold in packs of 5

* Bulk orders for individual O-Rings available upon request

Compatibility **POWER HOUSE!**



WC-1 Spool Gun Control

Easily connect your Prince[®] XL or Prince[®] SG spool gun to virtually any power supply. Simple connection that only requires 115V to power the unit and simple 2 wire connection to contactor

WC-1 Spool Gun Control

Part Number	001-3062
-------------	----------



All company names are trademarks[™] or registered[®] trademarks of their respective holders. Use of them does not imply any affiliation with or endorsement by them.



MK200 Contactor Box

The MK200 provides opening and closing contactors to power supply units that do not have contactors built in

MK200 Contactor Box

Part Number	001-3066
-------------	----------

Spool Gun Adapters

Generic, 24VAC All Source



Part Number	005-0264
-------------	----------

Lincoln, 42V 14-Pin C/D Trigger



Part Number	005-0676
-------------	----------

Miller, 24VAC 14-Pin A/B Trigger



Part Number	005-0261
-------------	----------

ESAB MigMaster 251



Part Number	005-0624
-------------	----------

Thermal Arc Fabricator 250



Part Number	005-0689
-------------	----------

Panasonic Gunslinger 260



Part Number	005-0617
-------------	----------



*Family Owned and Operated
Since 1966*



Cobra Welding Systems

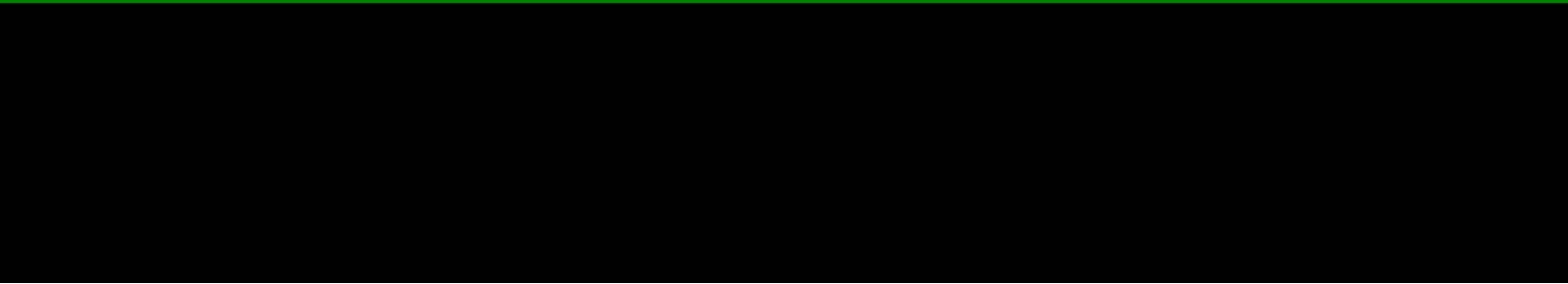
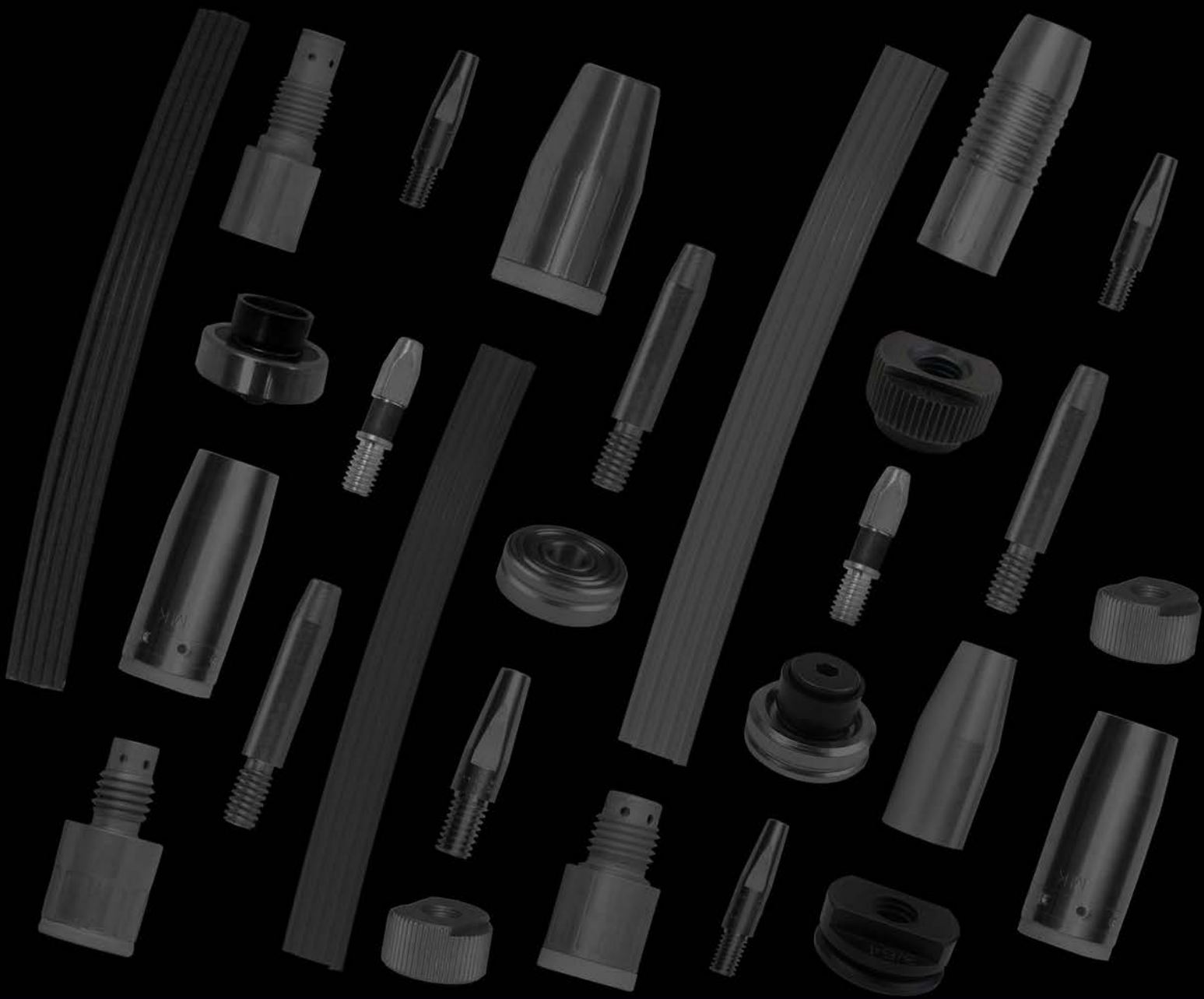

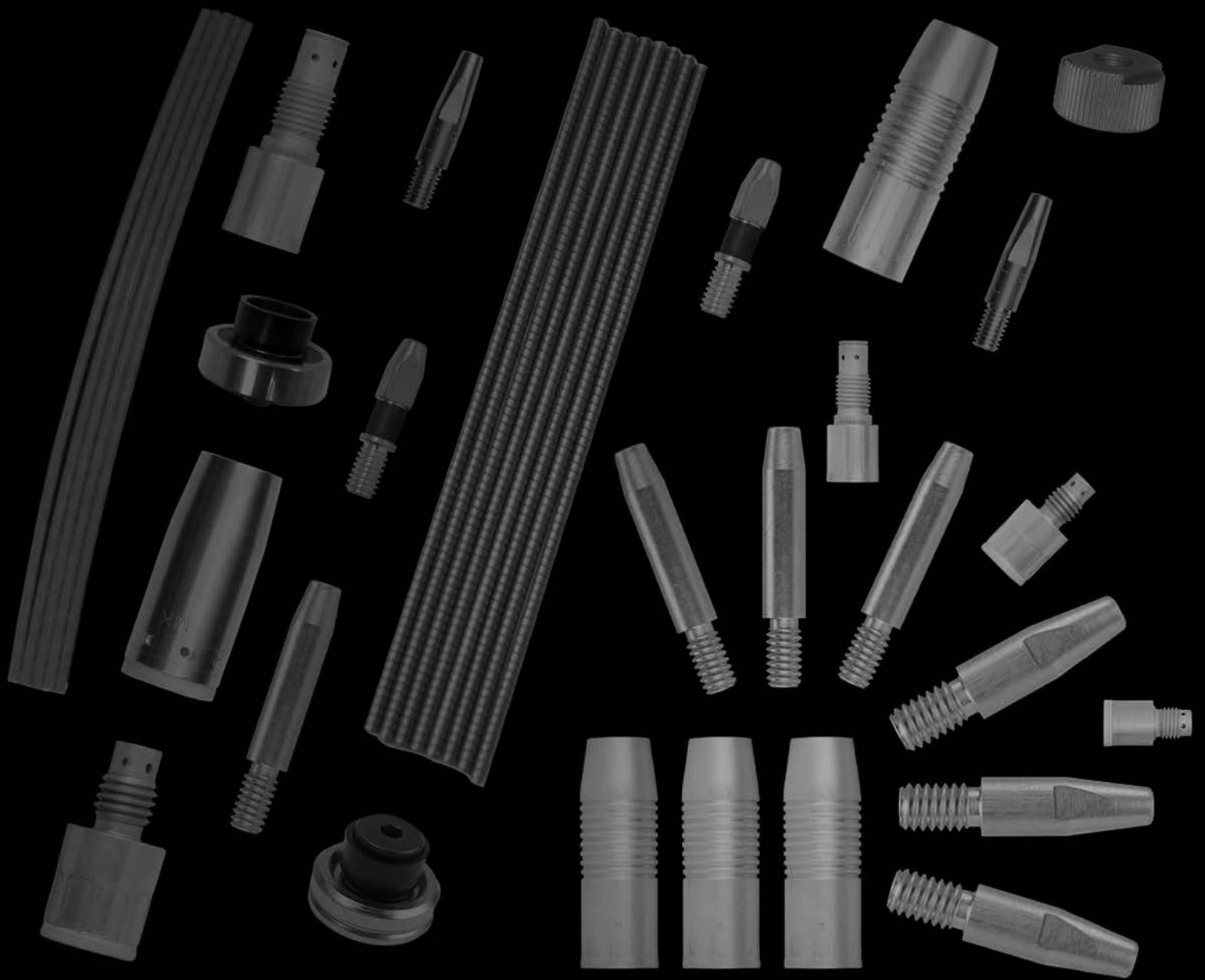

MIG
PUSH-PULL SYSTEMS

Accessories and Consumables

3/8" Contact Tips

Compatible Guns: Python®, Python® X, Python® LX, Prince® XL, Prince® X, Prince® XL Spool, Cobra® X-HD, Cobra® MX-HD, Cobra® Gold (Cobra Gold must use Cup adapter P/N 431-1630)

3/8" Diameter Aluminum Contact Tip

MK Products® most popular and reliable contact tip. Designed and created to ensure 100% delivery of weld power.



Aluminum

3/8 " Diameter Aluminum Contact Tip			
Part Number	Wire Size	Tip ID	ARC
621-0390-25	.030" (0.8 mm)	.041"	Spray
621-0391-25	.035" (0.9 mm)	.044"	Spray
621-0392-25	3/64" (1.0 mm)	.053"	Spray
621-0393-25	3/64" (1.2 mm)	.060"	Spray
621-0394-25	1/16" (1.6 mm)	.074"	Spray
621-0395-25	1/16" (1.6 mm)	.085"	Spray

Sold in packs of 25.

3/8" Diameter Spring Loaded Aluminum Contact Tip

Achieve superior arc control with MK Products® Spring Loaded Contact Tips. Wrap around spring design forces continual positive contact of wire with ID of tip. Highly recommended for pulse welding applications.



Aluminum

3/8" Diameter Spring Loaded Aluminum Contact Tip			
Part Number	Wire Size	Tip ID	ARC
621-0331	.030" (0.8 mm)	.041"	Spray
621-0332	.035" (0.9 mm)	.044"	Spray
621-0333	3/64" (1.0 mm)	.053"	Spray
621-0334	3/64" (1.2 mm)	.060"	Spray
621-0335	1/16" (1.6 mm)	.074"	Spray
621-0337	1/16" (1.6 mm)	.085"	Spray

Sold in quantities of 1.

Must use hard wire welding conduit and spiral steel barrel liner to weld hard wire

See pg. 83

3/8" Diameter Hard Wire Contact Tip

Convert your system to weld hard wire with premium, long lasting, genuine MK Products® Contact Tips. Recommended for steel, stainless steel and flux core wires.



Hard Wire

3/8" Diameter Hard Wire Contact Tip			
Part Number	Wire Size	Tip ID	ARC
621-0396-25	.030" (0.8 mm)	.041"	Short
621-0397-25	.035" (0.9 mm)	.044"	Short
621-0398-25	.045" (1.0 mm)	.053"	Short

Sold in packs of 25.



Also available:
Tip Wrench
(P/N 931-0044)
3/8" ONLY

1/4" Contact Tips

Compatible Guns: *Cobra® X, Cobra® MX, Cobra® Gold Guns*

1/4" Diameter Aluminum Contact Tip

Ensure optimum delivery of weld power with genuine MK Products® 1/4" contact tips.



Aluminum

1/4" Diameter Aluminum Contact Tip			
Part Number	Wire Size	Tip ID	ARC
621-0057-25	.023" (0.6 mm)	.031" (0.8 mm)	Spray
621-0325-25	.030" (0.8 mm)	.036" (0.9 mm)	Spray
621-0076-25	.030"/.035" (0.8/0.9 mm)	.041" (1.0 mm)	Spray
621-0001-25	.035" (0.9 mm)	.044" (1.1 mm)	Spray
621-0327-25	3/64" (1.2 mm)	.053" (1.37 mm)	Spray
621-0003-25	3/64" (1.2 mm)	.060" (1.5 mm)	Spray
621-0075-25	1/16" (1.6 mm)	.074" (1.9 mm)	Spray
621-0153-25	1/16" (1.6 mm)	.085" (2.1 mm)	Spray

Sold in packs of 25 only

****Must use hard wire welding conduit and spiral steel barrel liner to weld hard wire****

See pg. 83

1/4" Diameter Hard Wire Contact Tip

Convert your system to weld hard wire with premium, long lasting, genuine MK Products® Contact Tips. Recommended for steel, stainless steel, and flux core wires.



Hard Wire

1/4" Diameter Hard Wire Contact Tip			
Part Number	Wire Size	Tip ID	ARC
621-0326-25	.030" (0.8 mm)	.036" (0.9 mm)	Short
621-0077-25	.035" (0.9 mm)	.041" (1.0 mm)	Short
621-0002-25	.035" (0.9 mm)	.044" (1.1 mm)	Short

Sold in packs of 25 only

3/8" - 48° Curved Cup and Tips

For Air and Air/Water Barrels

Expand the aluminum welding capabilities of your Python®, Python® X, Python® LX, Prince® XL, Prince® X welding gun with the addition of a Curved Gas Cup and Contact Tip. Made to fit all current production Straight, Air/Water and Air Cooled barrels for the Python®, Python® X, Python® LX, Prince® XL, Prince® X. The simple, curved design of these tips establishes greater electrical contact with the welding wire; enhancing arc strikes and arc characteristics. The narrow profile of the Curved Gas Cup (3/4" outside diameter) enables the operator to reach in and weld in very tight spaces, seams or gaps.

To adapt the curved front-end assembly to your straight barrel, choose from the part numbers shown below

1 Choose Your 48° Curved 3/8" Tip:



*Length of weld and heat may determine tip size

48° Curved Tips		
Part Number	Wire Size	Tip ID
621-0451	.035"	.044"
621-0452	.040" & 3/64"	.053"
621-0453	3/64"	.060"
621-0454	1/16"	.074"

2 Add these required parts:



Curved Gas Cup	
Part Number	621-0425

Chrome Nut	
Part Number	449-0193

Curved Tip Adapter	
Part Number	003-2230

EZ-Lock® Barrels

Only compatible with EZ-Lock® guns (Python® X, Python®, Python® LX, Prince® X, Prince® XL, and Prince® XL Spool Guns)

6 Inch

Straight



P/N 003-2151
(Air/Water)



P/N 003-2380
(300AMP Water Cooled)



P/N 003-2315
(400AMP Water Cooled)

45 Degree, Curved (Recommended for Prince® XL)



P/N 003-2152
(Air/Water)



P/N 003-2381
(300AMP Water Cooled)



P/N 003-2316
(400AMP Water Cooled)



P/N 003-2467
(400AMP Water Cooled)
4" Radius: For hard wires

60 Degree, Curved (Python® Only)



P/N 003-2147
(Air/Water)



P/N 003-2382
(300AMP Water Cooled)



P/N 003-2317
(400AMP Water Cooled)

12 Inch

Straight



P/N 003-2156
(Air/Water)



P/N 003-2318
(400AMP Water Cooled)

45 Degree, Curved



P/N 003-2158
(Air/Water)



P/N 003-2319
(400AMP Water Cooled)

18 Inch

Straight



P/N 003-2157
(Air/Water)



P/N 003-2320
(400AMP Water Cooled)

45 Degree, Curved



P/N 003-2159
(Air/Water)



P/N 003-2321
(400AMP Water Cooled)

EZ-Lock® Flex Barrels

Designed for hard to reach welds!

MK Products® Flex Barrels

Only compatible with EZ-Lock® guns (Python® X, Python®, Python® LX, Prince® X, Prince® XL, and Prince® XL Spool Guns)

Key Features

- Can also be used for hard wire welding
- Air Cooled Only
- 200AMP @ 60% duty cycle
- Available in 4 lengths

MK Products® Flex Barrels		
Part Number	Description	Flexibility
003-2495-12	Flex Barrel Assembly, 12"	0 - 90°
003-2495-18	Flex Barrel Assembly, 18"	0 - 135°
003-2495-24	Flex Barrel Assembly, 24"	0 - 180°
003-2495-36	Flex Barrel Assembly, 36"	0 - 180°

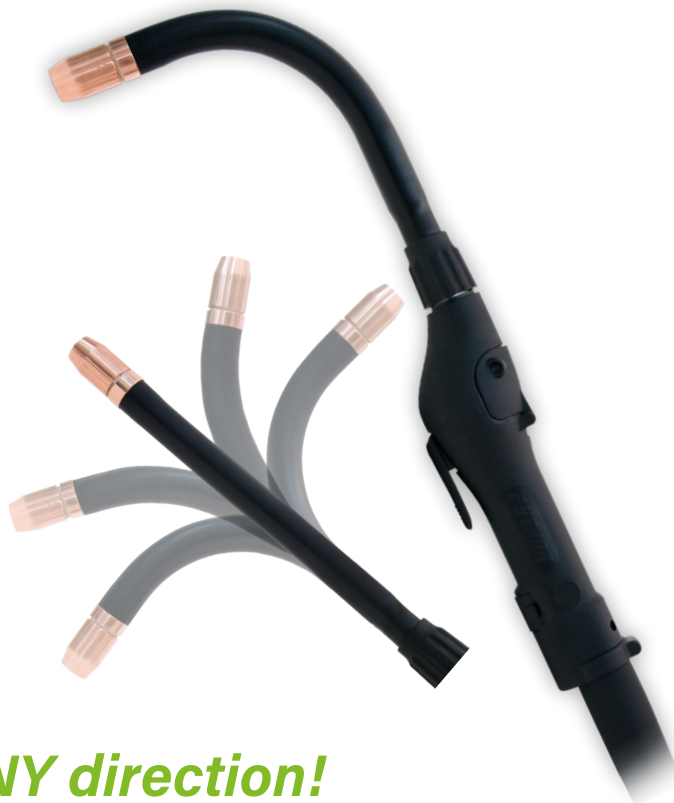

Bends in ANY direction!



3/8" Diameter Flex Barrel Tips			
Part Number	Wire Size	Tip ID	ARC
621-0480-25	.030" (0.8 mm)	.041" (1.0 mm)	Spray
621-0481-25	.035" (0.9 mm)	.044" (1.1 mm)	Spray
621-0482-25	3/64" (1.2 mm)	.053" (1.37 mm)	Spray
621-0483-25	3/64" (1.2 mm)	.060" (1.5 mm)	Spray

sold in packs of 25



Flex Barrel Cup		
Part Number	ID	Cup Number
621-0465	1/2" (12.7 mm)	8
621-0466	5/8" (15.9 mm)	10

Flex Barrel Aluminum Liners	
Part Number	Length
615-0260-12	12"
615-0260-18	18"
615-0260-24	24"
615-0260-36	36"

Flex Barrel Spiral Steel Liners	
Part Number	Length
615-0261-12	12"
615-0261-18	18"
615-0261-24	24"
615-0261-36	36"

Drive Rolls

Insulated drive roll kits are made to eliminate micro arcing at the drive roll and force contact to the tip to insure positive transfer of weld power directly to the wire where it counts. Welding in a Pulse mode? Every pulse counts... don't miss one with insulated drive rolls.

Insulated Grooved Drive Roll Kit

To maximize performance and minimize deformation of the wire, these drive rolls have been uniquely designed for each wire size specifically. Available for aluminum wire in the following sizes: .030", .035", .040", 3/64", 1/16"



Insulated Grooved Drive Roll Kit	
Part Number	Wire Size
005-0715	.030 (0.8 mm)
005-0716	.035 (0.9 mm)
005-0717	.040 (1.0 mm)
005-0718	3/64" (1.2 mm)
005-0719	1/16" (1.6 mm)

Kit includes both idler roll and drive roll

Insulated Knurled Drive Roll Kit

Weld with a few wire sizes? The insulated knurled drive roll kit will still give you the comfort of knowing positive contact is being made at the tip with the freedom to switch between different wires sizes. Drive roll is hardened to insure a longevity.



Insulated Knurled Drive Roll Kit	
Part Number	Wire Size
005-0363	.030" - 1/16" (0.8 mm - 1.6 mm)

Kit includes both idler roll and drive roll

Idler Roll Wire Feed Assembly Kit

Idler rolls are designed to feed aluminum or hardwire. Kit includes idler roll, lock washer and screw



Idler Roll Wire Feed Assembly Kit	
Part Number	Wire Size
005-0686	.030" - 1/16" (0.8 mm - 1.6 mm)

Kit includes idler roll, lock washer and screw

Knurled Drive Roll

Knurled drive rolls are designed to allow the wire to have more surface area contact. This extra contact means more grip and traction



Knurled Drive Roll	
Part Number	Wire Size
511-0101	.030" - 1/16" (0.8 mm - 1.6 mm)



**Drive Roll
Removal Tool**
(P/N 931-0100)

Barrel Liners - Aluminum

Heavy Duty Barrel Liner

For Python® X, Python®, Python® LX, Cobra® X, Cobra® X-HD, Cobra® MX, Cobra® MX-HD, Prince® XL, Prince® XL Spool Gun, Prince® X, and Prince® SG Spool Gun.



Heavy Duty Barrel Liner	
Part Number	Wire Size
931-0145	.040" - 1/16" (1.2mm - 1.6mm)

**Sold in packs of 5*

Recommended for Aluminum wire size .040" - 1/16"

Barrel Liner

For Python® X, Python®, Python® LX, Cobra® X, Cobra® X-HD, Cobra® MX, Cobra® MX-HD, Prince® XL, Prince® XL Spool Gun, Prince® X, and Prince® SG Spool Gun.



Barrel Liner	
Part Number	Wire Size
931-0137	.030" - .035" (0.8mm-0.9mm)

**Sold in packs of 5*

Recommended for Aluminum wire size .030" - .040"

Green Barrel Liner

Barrel liner for all early Cobra® model guns.



Green Barrel Liner	
Part Number	Wire Size
931-0135	.030" - 1/16" (0.8mm - 1.6mm)

**Sold in packs of 5*

Recommended for Aluminum wire size .030" - 1/16"

Heavy Duty Barrel Liner- SOLD BY THE FOOT

For Python® X, Python®, Python® LX, Cobra® X, Cobra® X-HD, Cobra® MX, Cobra® MX-HD, Prince® XL, Prince® XL Spool Gun, Prince® X, and Prince® SG Spool Gun.

Heavy Duty Barrel Liner	
Part Number	Wire Size
615-0186	.040" - 1/16" (1.2mm - 1.6mm)

10ft minimum

Recommended for Aluminum wire size .040" - 1/16"

Sold in 10ft. increments - 10ft., 20ft., etc.

Barrel Liner - SOLD BY THE FOOT

For Python® X, Python®, Python® LX, Cobra® X, Cobra® X-HD, Cobra® MX, Cobra® MX-HD, Prince® XL, Prince® XL Spool Gun, Prince® X, and Prince® SG Spool Gun.

Barrel Liner	
Part Number	Wire Size
615-0178	.030" - .035" (0.8mm-0.9mm)

10ft minimum

Recommended for Aluminum wire size .030" - .040"

Sold in 10ft. increments - 10ft., 20ft., etc.

Green Barrel Liner - SOLD BY THE FOOT

Barrel liner for all early Cobra® model guns.

Green Barrel Liner	
Part Number	Wire Size
615-0054	.030" - 1/16" (0.8mm - 1.6mm)

10ft minimum

Recommended for Aluminum wire size .030" - 1/16"

Sold in 10ft. increments - 10ft., 20ft., etc.

Hard Wire Accessories

EZ-Lock® Barrels - Spiral Steel Barrel Liner

For Air and Water Cooled Barrels. Python®, Python® LX, Prince®, Prince® XL (60° barrels are not compatible with any Prince® style guns)

Spiral Steel Barrel Liner			
Part Number	Barrel Length	Liner Length	Description
615-0343	6"	7.58"	Straight, 45°Curved
*615-0252	6"	8.73"	Straight, 45°Curved <i>(*Use with Tip Extender*)</i>
615-0338	6"	7.35"	60° Curved
*615-0250	6"	8.45"	60° Curved <i>(*Use with Tip Extender*)</i>
615-0258	12"	12.135"	Straight, 45°Curved
615-0259	18"	18.127"	Straight, 45°Curved

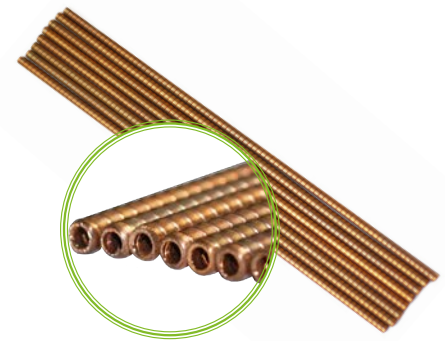

Reference image for all Spiral Steel Liners (lengths differ)

Fixed Barrels - Spiral Steel Barrel Liner

For Air and Water Cooled Barrels

Compatible Guns: Cobra® MX (MX & MX-HD)			
Part Number	Barrel Length	Liner Length	Description
615-0341	6"	5.63"	Fixed Barrel
*615-0248	6"	6.70"	Fixed Barrel <i>(*Use with Tip Extender*)</i>

EZ-Lock® Flex Barrels - Spiral Steel Barrel Liner

For Air Cooled Barrels ONLY

Compatible Guns: Python®, Python® LX,			
Part Number	Barrel Length	Liner Length	Description
615-0261-12	12"	12"	FLEX BARREL
615-0261-18	18"	18"	FLEX BARREL
615-0261-24	24"	24"	FLEX BARREL
615-0261-36	36"	36"	FLEX BARREL

Compatible Guns: Prince® XL, Spool			
Part Number	Barrel Length	Liner Length	Description
615-0353-12	12"	12"	FLEX BARREL
615-0353-18	18"	18"	FLEX BARREL
615-0353-24	24"	24"	FLEX BARREL
615-0353-36	36"	36"	FLEX BARREL

Hard Wire Welding Conduits

(Steel, Stainless Steel, Flux Core, etc...)

Use MK Spiral Steel Conduit for all MK Product connection guns

MK Spiral Steel Conduit	
Part Number	Length
615-0208	15 ft
615-0216	25 ft
615-0219	35 ft
615-0218	50 ft

Use Spiral Steel Conduit for all X Series and compatible guns

Spiral Steel Conduit	
Part Number	Length
615-0621-15	15 ft
615-0621-25	25 ft
615-0621-35	35 ft
615-0621-50	50 ft

COBRA TIMES

Can't let go of the Old Cobra?

Est. 1969

Wednesday, September 10, 1995

JK2017

Still holding on to that old Cobra®, we don't blame you. The Cobra® gooseneck gun set the bar high for all push-pull guns with the most stable arc in the welding industry! Introduced in 1966 the Cobra® pioneered the concept of easily feeding aluminum wire and was patented as the first push-pull gooseneck gun. When it came to comfort, durability, and performance, nothing could beat a Cobra® gun. We invite you to explore our new products but can understand why your comfort remains with the gun that started it all. As a service to our loyal customers that have been using Cobra® guns for decades, we wanted to make sure you know that we still provide many of the parts, accessories and consumables that keep your Cobra® performing at its best. MK Products® has been manufacturing quality Push-Pull MIG guns for over 50 years and has grown and adapted to the rapid changes in the welding industry. Remaining on the cutting edge of technology with a wide variety of products and customers, gives us the confidence to say "We are the leader in Push-Pull MIG guns".



Find replacement parts

Accessories and Consumables

Page Number	Category	Description
Page 76 & 77	Contact Tips	3/8" & 1/4" Diameter Aluminum Contact Tip charts
Page 83	Drive Rolls	All Compatible
Page 84	Barrel Liners	Green Barrel Liner (Aluminum only)

Hard Wire Liners

Part Number	Liner Material	Note
615-0284	Spiral Steel	
615-0057	Spiral Steel	Use with tip extender (P/N 621-0017)

Cobra Hall of FAME

Starting in 1966, the Cobra guns started the Aluminum Push-Pull evolution. What started as an air gun in 1966 quickly adapted to the demanded electric style a little after 1971.



Gas Cups, Gas Cup Adapters, and Tips Extenders

Recommended Spare Part List

Part Number	Description	Part Number	Description
615-0601-15	Conduit 15 ft	449-0542	Nut, Pot
615-0601-25	Conduit 25 ft	005-0255	Handle Kit
615-0601-50	Conduit 50 ft	511-0101	Drive Roll
005-0656	Potentiometer	005-0686	Idler Roll
003-0568	Micro Switch	931-0100	Drive Roll Removal Tool
401-0521	Knob, Pot	931-0584	Gas Valve Tool
303-0540	'O' Ring, Pot		

Heavy Duty Gas Cup Adapter

Part Number	431-1630
-------------	----------

Tip Extender

Part Number	621-0017
-------------	----------

Gas Cups

Part Number	ID	Size
621-0079	1/4" (6.4 mm)	5
001-0137	3/8" (9.5 mm)	6
001-0138	1/2" (12.7 mm)	8*

Finned Gas Cups

Part Number	ID	Size
621-0249	1/2" (12.7 mm)	8
621-0250	5/8" (15.8 mm)	10
621-0251	5/8" (15.8 mm)	10HD
621-0252	3/4" (19.05 mm)	12HD

Heavy-Duty Gas Cups

Part Number	ID	Size
621-0366	1/2" (12.7 mm)	8
621-0367	5/8" (15.8 mm)	10

*Sold in packs of 4

Lead Assembly

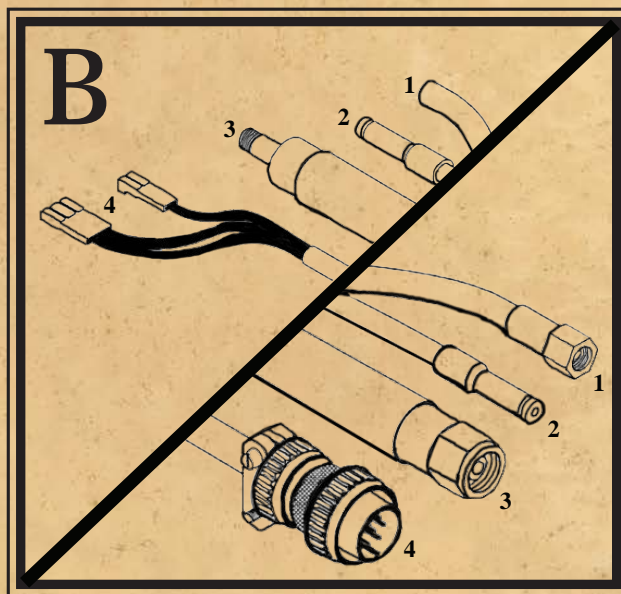
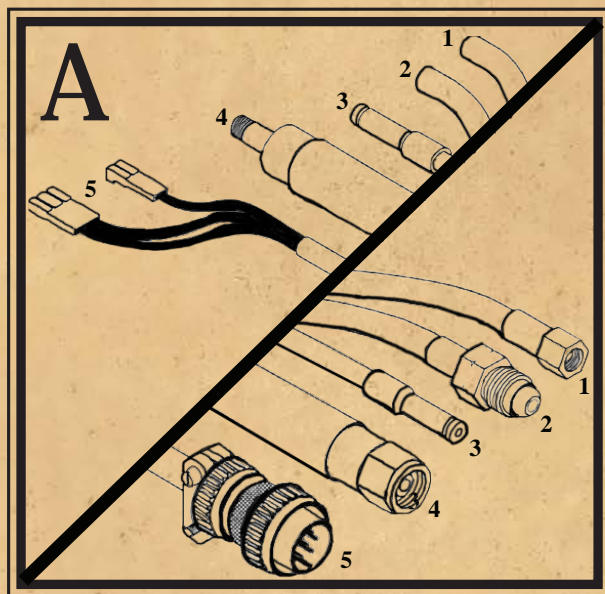

A

- 1 Gas Hose
- 2 Water Hose
- 3 Wire Conduit
- 4 Water/Power Cable
- 5 Electrical Cable

210 Series Water Cooled Cable Assemblies

Length	Conduit	#4 Water/ Power Cable	Electrical Cable	Gas Hose	Water Hose	Snake Skin
15 ft	615-0601-15	001-2521	005-0268	001-0537	001-0529	931-0110
25 ft	615-0601-25	001-2524	005-0269	001-0538	001-0530	931-0122
50 ft	615-0601-35	843-0338	005-0272	001-0665	001-0667	931-0123

B

- 1 Gas Hose
- 2 Wire Conduit
- 3 Power Cable
- 4 Electrical Cable

211 Series Ultra-Flex Cable Assemblies

Length	Conduit	Power Cable	Electrical Cable	Gas Hose	Snake Skin
15 ft	615-0601-15	001-2527	005-0268	001-0537	931-0110
25 ft	615-0601-25	001-2528	005-0269	001-0538	931-0122
50 ft	615-0601-35	001-1042	005-0272	001-0665	931-0123





CobraTurn® *Turntables*



Includes 10" tabletop and On/Off Foot Switch



CobraTurn® T-260

Impressed with the Aircrafter T-250? Check out the newly redesigned CobraTurn T-260 packed with unique features to make your job easier. MK Products has incorporated over 40 years of turntable manufacturing in to this durable yet precision CobraTurn T-260 model. Boasting many new features and improved performance, this is one turntable you can't pass up. With the ability to turn small parts up to large parts with a 260lb capacity, you won't find your head spinning to complete your projects.

CobraTurn® T-260	
Model Number	127-008

Key Features:

- Tabletop de-clutch release
- Weld ground fault protection
- Digital RPM control
- Linear single speed control knob with center push button start, stop and jog functions
- Gas ID purge through center shaft
- High frequency interference protection
- Easily bolts to any flat surface
- Durable powder coat finish
- Billet aluminum gear housing
- Heavy-duty steel cut gears
- Quick adjustable tabletop
- Appropriate for all welding applications

Optional Accessories



Heavy Duty Variable Speed Foot Control	
Part Number	005-0746



Self-Centering 3 Jaw Chuck	
Part Number	005-0812

Specs:

- **Balanced Load Capacity - Horizontal:**
 - 260 lbs Horizontal
- **Balanced Load Capacity - Vertical:**
 - 130 lbs Vertical & Centered 7" Max from the table
- **Turntable Diameter:**
 - 10"
- **Degree Tilt**
 - 0° - 90° in 15° increments
- **Speed Range R.P.M.**
 - 0.1 - 6
- **Ground Capacity AMPS**
 - 400A 60% Duty Cycle
- **Input Voltage**
 - 120VAC 50/60 Hz
- **Shipping Weight**
 - 38 lbs

Includes two sets of manually adjustable jaws from 7/8" - 3 3/4" internal and 1/8" - 4" external clamping.



Includes 5" tabletop and On/Off Foot Switch



CobraTurn® T-30

The CobraTurn® T-30 turntable is ideal for lightweight applications. The most affordable rotary turntable, the T-30 is well suited for welding small, intricate assemblies, tube flanges and small aircraft-type parts as well as rotating lightweight non-welding items. The compact T-30 turntable has a maximum center load capacity of 30 lbs. and maximum welding ground capacity of 400 amps.

CobraTurn® T-30	
Model Number	125-001

Key Features:

- Compact high performance turntable
- Weld ground fault protection
- Adjustable LED illuminated control panel
- Linear single speed control knob with center push-button start, stop and jog functions
- Cam lever to lock table angle
- High frequency interference protection
- Easily bolts to any flat surface
- Appropriate for all welding applications

Optional Accessories

	
Heavy Duty Variable Speed Foot Control	
Part Number	005-0746
	
Self-Centering 3 Jaw Chuck	
Part Number	005-0812

Includes two sets of manually adjustable jaws from 7/8" - 3 3/4" internal and 1/8" - 4" external clamping.

Specs:

- **Balanced Load Capacity - Horizontal:**
 - 30 lb
- **Balanced Load Capacity - Vertical:**
 - 15 lb
- **Turntable Diameter:**
 - 5"
- **Degree Tilt**
 - 0° - 90°
- **Speed Range R.P.M.**
 - 0.2 - 10
- **Ground Capacity AMPS**
 - 400A 60% Duty Cycle
- **Input Voltage**
 - 120VAC 50/60 Hz
- **Shipping Weight**
 - 14 lbs

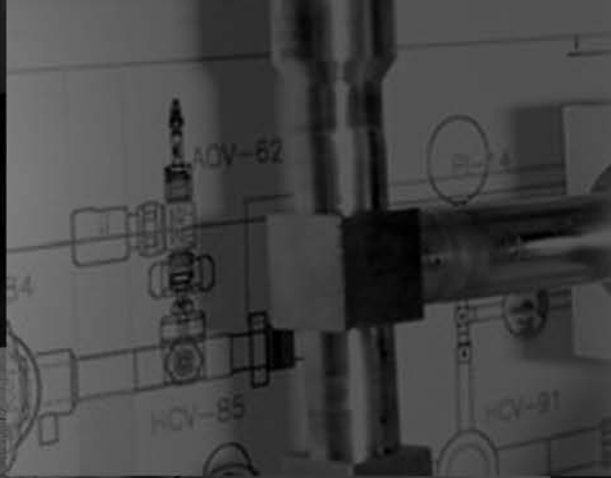



Orbital[™]
Orbital[®] Systems

What you need for a complete Orbital System...

Pick a Power Supply

1.

CobraTig® 150

(See pg. 94)



Cooler

2.

CobraCooler®

(See pg. 95)



Optional Cooler that provides recirculation of water for weldheads that have provisions for water cooling

Compatible with both Power Supplies

WeldHeads

3.

MiniMicro®

(See pg. 100)



4000
1/8-1/2" OD



5001
1/8-1" OD

View Collets and Tungsten list on pg. 103-108

Advanced Color Logic® ●
(See pg. 96)



CopperHeads® ●
(See pg. 99)



5002
1/4"-2" OD



5003
1/2"-3" OD

DiamondBack® ●
(See pg. 98)



5006
2"-6" OD

View Collets and Tungsten list on pg. 103-108



CobraTig® 150

The CobraTig® 150 is a portable, lightweight orbital welding power source with a digital controller that is the perfect solution for construction or rugged environments. User friendly LCD screen and simple menu guide users through powerful weld programming using SmartArc® logic, real-time data monitoring, plus a built-in thermal printer for weld data. Packaged for rugged construction environments or manufacturing work-cells.

Key Features:

- Provides automatic control for repeatability, verification and traceability
- SmartArc software develops a near ideal weld procedure with Automatic Program Generator
- Capable of going down to 0.1 Amps with MicroTig™ technology
- High Voltage Pulse automatic arc starting from 0.5 to 25 Amps
- SmartArc control provides flexibility for orbital and manual welding
- Shipped in a sealed rugged case with wheels for easy mobility
- Standard with extended memory

CobraTig® 150	
Model Number	254-153

Line Power (+/- 10%)
100 VAC 50/60 Hz Single Phase, 15A
120 VAC 50/60 Hz Single Phase, 15A
208 VAC 50/60 Hz Single or Three Phase, 30 A
230 VAC 50/60 Hz Single or Three Phase, 30 A

Popular Accessory



MicroTig Manual Weld Kit	
Part Number	005-0670

Thermal Printer Paper (5 per. pkg.)	
Part Number	921-0170

Specs:

Technical Information

Line Power (+/-10%): 100 VAC 50/60 Hz Single Phase, 15A
 120 VAC 50/60 Hz Single Phase, 15A
 208-220/230-240 VAC 50/60 Hz Single or Three Phase, 30A

Output Current: 0.1~150A (+/-1%), Constant or Pulsed

Minimum Arc Starting: 0.5 to 25 AMPS

Pulse Rate: 0.01 to 2.25 Seconds Per Pulse

Arc Voltage: 65 VDC Open Circuit, up to 26 welding VDC

Loop Response: 1.5 KHz

Current Regulator Freq: 30 KHz

Motor Control: 24 VDC, 2A min., DC Tachometer Feedback

Memory Storage: 25 Weld Procedures

Mechanical Information: Weight: 42 lbs. / 19.1 Kg

Height: 14 in. / 35.6 cm

Width 8.5 in. / 21.6 cm

Length: 19 in. / 48.3 cm

CobraCooler®

Portable Coolant Recirculation

This recirculator is a separate stand-alone unit that conveniently attaches mechanically to an MK Products® CobraTig® 150 welding power source.



Key Features:

- Provides water cooling for any MK Water Cooled weldhead
- Includes high impact shipping case
- Note: MiniMicro™ requires the Cobra Cooler®

Specs:

Technical Information

Line Power: 120VAC 50/60 HZ, Single Phase ONLY

Reservoir Capacity: Approximately 1 gal/ 3.78 L
On level surface, fill per requirements indicated on the site gauge on front of the CobraCooler®

Coolant Type: Use Cobra® Coolant (Aluminum Protection) P/N 931-0060. Cobra® Coolant does not contain reactive sulphur or chlorine and does not react with copper, brass or aluminum

System Pressure: Maximum system pressure is 21.75 PSI as specified by the pump manufacturer

Electrical Information

Pump: 12 Volt DC, 2 amps

AC Power for Cooling Unit: Panel switchable, rear panel fuse holder

Front Panel Indicators: Spinning Flow Indicator

Mechanical Information

Dry Weight: 13.9 lbs. / 6.30 kg

Height: 5.5 in. / 14.0 cm

Width: 8.5 in. / 21.6 cm

Depth: 19 in. / 48.3 cm

CobraCooler®	
Model Number	250-153

For BEST performance, use only Cobra® Coolant!



Failure to use Cobra® Coolant may **VOID** warranty

1 Gallon (3.78L)		1 Case (4Gal / 1Gal ea.)		5 Gallon (18.9L)	
Part Number	931-0060	Part Number	931-0060-4	Part Number	931-0060-5GAL



Advanced Color Logic®

GTAW Orbital Power Supply / Controller

The patented Advanced Color Logic® power supply delivers controlled welding current needed to perform high-integrity orbital tube welds and is the perfect package for manufacturing environments. Exclusive Auto Program Generator for easy weld setup and retrieval of saved procedures. Repeatability and precision, combined with real time data monitoring, traceability, and verification conform to most inspection and quality requirements. Pentium® class processor for the fastest real time on-screen visual display of all welding parameters. Playback entire weld graphically for analysis or download to off-line computer.

Key Features:

- Digital control and real-time graphics provide ease of operation and on-screen reference
- Make your next weld while viewing the process in real time with 17" LCD flat screen monitor
- Patented updated software now delivers more information, faster
- USB equipped for moving, storing and transferring weld data and procedures
- Programming is easy: just enter the tube diameter and wall thickness
- Weld data monitoring can be printed or viewed as text, graphic on-screen displays or exported to a spreadsheet file

Specs:

Technical Information

Line Power: 120 VAC (+/-10%) 50/60 Hz.
 208-240 VAC (+/-10%) single phase, 50/60 Hz.
 208-240 VAC (+/-10%) three phase, 50/60 Hz.

Output Current: 1 to 200 AMPS (+/-10%) constant or pulsed

Pulse Rate: 0.01 to 9.99 seconds per pulse

Arc Voltage: 80VDC open circuit, up to 20VDC during welding

Loop Response: 3KHz

Current Regulator

Frequency: 18KHz

Motor Control: 24V, 2 AMP maximum, DC tachometer feedback or back EMF (optional)

Mechanical Information

Width: 16.75 inches

Height: 16.75 inches

Depth: 27.5 inches

Weight: 110 lbs. (ACL only)

Shipping Weight: 350 lbs. (includes ACL, monitor, printer, keyboard, power cable and customer start-up kit; palletized)

Advanced Color Logic®

Model Number	254-203
--------------	---------

Line Power (+/- 10%)

120VAC 50/60 Hz Single Phase, 15A
 120VAC 50/60 Hz Single Phase, 15A, UL
 208/240VAC 50/60 Hz Single or Three Phase, 30A

Alternative or Additional Input Power Cords

- 120 VAC, Single Phase (P/N 843-0600)
- 208/240 VAC, Single Phase (P/N 843-0602)
- 208/240 VAC, Three Phase (P/N 843-0603)
- 220 VAC, Single Phase, Euro (P/N 843-0601)
- Universal 120 VAC, 30 A UL (P/N 843-0613)

Popular Accessory

- Orbital Power Supply Calibration Kit (P/N 005-0698)
- Hand held kit (P/N 005-0803)

VPAC®

GTAW Orbital Power Supply / Controller



The VPAC (Variable Polarity-Alternating Current) module, is an add-on accessory to the ACL Orbital tube welding system. Incorporating a VPAC in to your system will provide access to the advanced parameters for AC welding with full control over pulse time in straight and reverse polarities. The ability to change parameters at each individual weld level gives the user complete control over the entire weld.

VPAC®	
Model Number	001-1575

Key Features:

- Variable Polarity Alternating Current
- Ability to change weld parameters at each individual weld level
- Unlocks advanced features and parameters
- Full control over pulse time in straight and reverse polarities
- Complete control over entire weld

Specs:

Technical Information

Power: 120 VAC (+/-10%) 50/60 Hz, 0.5A

Current Capability: 200 AMPS (throughput)

Fuse: 1 AMP, 250V (AGC Type)

Dimensions: 23" L X 5.8"H X 13.25"W

Weight: 25.0 lbs.



DiamondBack™

The DiamondBack™ is our largest in-place orbital weld head. Heavy duty and versatile, the DiamondBack™ has a narrow profile and is perfect for process piping and weld fitting applications found in food & beverage, dairy and other sanitary process piping installations. Also great for high-pressure aerospace applications, this easy to use weld head is simple yet robust to meet the demands of field construction or manufacturing production environments.

Key Features:

- Weldable Tube Range: 2" Tube OD to 6" Tube OD
- Weldable Nominal Pipe Range: 2" nominal pipe to 5" nominal pipe
- 3 Piece collet design for precision self-centering of tube or pipe
- Operator flexibility: flip-top and view lens aid fit-up, alignment & inspection
- Ergonomically perfect with 7 function, push button fingertip control built into the weld head
- Advanced design includes jaw style clamping, 360° head rotation and 90° tilt action. rugged machined aluminum handles eliminates handling of weld head body
- Cable length of 25ft (7.6m)

Specs:

Technical Information

Power Cable Size: #6, 75A, 600V.
Twist-lock cable-end connectors.

Gas Hose Size: Nylon Tube, 1/4" OD x 0.17 ID
Double-end shut-off coupler 1/4"

Water Hose Size: Nylon Tube, 1/4" OD x 0.17" ID
fitting quick connector 1/4"

Control Cable Specification: 20AWG, 12 conductor

DiamondBack®			
Model Number	Tube Diameter Range	Pipe Diameter Range	Cooling
5006	2" - 6" O.D	2" - 5" NP	No

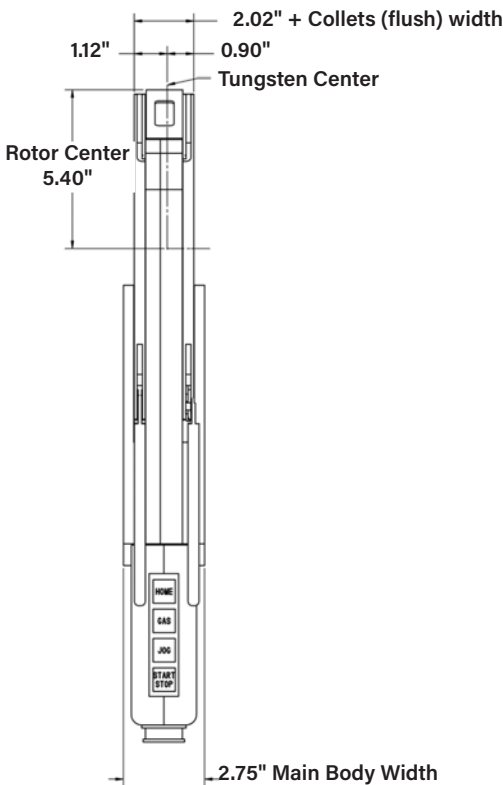

Popular Accessory



Reference Image



DiamondBack® Bench Mount	
Part Number	
005-0680	

Extension Cables	
Length	Part Number
25 ft	005-0635
50 ft	005-0635-50

CopperHead®

Whether it's for bench or portable applications, MK Products® provides a solution when it comes to orbital welding systems. As our most cost effective and rugged in-place orbital weld head, the CopperHead® series is an ideal cost saver for sanitary and high pressure tube systems. All CopperHeads® are Water Cooled with fingertip controls in the weld head handle and come ready to plug into the CobraTig® 150 SM and Advanced Color Logic® power sources.

Key Features:

- Weldable tube range: 1/8" - 3" tube OD
- Weldable nominal pipe range 1/2" - 2 1/2" NP
- 2 piece collet design
- Uses a 24VDC motor with TACH feedback
- Twist-lock cable-end connectors
- Connects directly to either the CobraTig® 150 or the ACL orbital power supply with the addition of Pig Tails and the CobraCooler®
- Cable length of 25ft (7.6m)

Specs:

Technical Information

Power Cable Size: #6, 75A, 600V.

Twist-lock cable-end connectors.

Gas Hose Size: Nylon Tube, 1/4" OD x 0.17 ID

Double-end shut-off coupler 1/4"

Water Hose Size: Nylon Tube, 1/4" OD x 0.17" ID

fiting quick connector 1/4"

Control Cable Specification: 20AWG, 12 conductor

Popular Accessory



Reference Image



CopperHead® Bench Mount

Part Number	005-0634
-------------	----------

Extension Cables

25 ft	005-0635
50 ft	005-0635-50



CopperHead®

Model Number	Tube Diameter Range	Pipe Diameter Range	Cooling
5001	1/8" - 1" O.D	1/8" - 1/2" NP	Yes
5002	1/4"- 2" O.D	1/2" - 1 1/2"	Yes
5003	1/2" - 3" O.D	1/4" - 2 1/2"	Yes

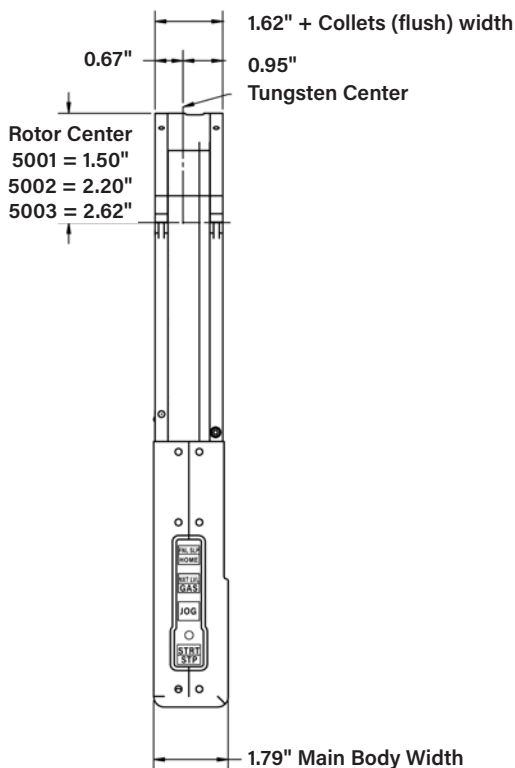



Coolant: For this weld head only, use distilled water.

MiniMicro™

The MiniMicro™ weld head was designed for precision welding of small diameter tubes and fittings. Controlled by either of our power supplies, this weldhead will turn the rotor at the precise speed to create a near perfect weld.

Key Features:

- Uses a 24VDC motor with Tach. feedback
- Capable of welding 1/8" to 1/2 inch OD tubes and associated fittings
- Twist-lock cable-end connectors
- Comes equipped with an integrated 12 foot cable
- Connects directly to either the CobraTig® 150 or the ACL orbital power supply with the addition of Pig Tails and the CobraCooler®

Specs:

Technical Information

Power Cable Size: #6, 75A, 600V.
Twist-lock cable-end connectors.

Gas Hose Size: Nylon Tube, 1/4" OD x 0.17 ID
Double-end shut-off coupler 1/4"

Water Hose Size: Nylon Tube, 1/4" OD x 0.17" ID
fitting quick connector 1/4"

Control Cable Specification: 20AWG, 12 conductor

MiniMicro®		
Model Number	Tube Diameter Range	Cooling
4000	1/8" - 1/2" O.D	Yes

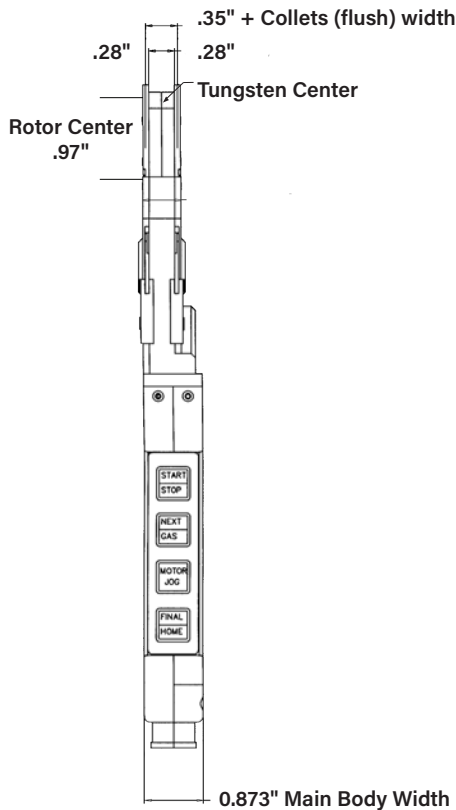

Popular Accessory



Reference Image



CopperHead® Bench Mount

Part Number	005-0634
-------------	----------

Extension Cables

25 ft	005-0635
-------	----------



Sanitary, Short Ferrule Collets

Easy to use and cost effective collets to simplify your orbital welding applications. MK strives to make your job easier by providing off-the-shelf solutions to life's tough challenges. Collets designed for precise tungsten placement offer enhanced repeatability for each weld



High-Pressure Weld Tooling

Custom machined collets combined with locating and threaded weld fitting mandrels position the electrode right where you want it. MK's ability to create standard and custom tooling can help make the difference in your critical welding applications, including aerospace

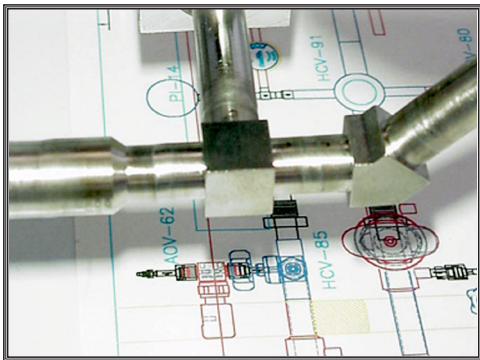

Sanitary - High-Pressure - Ultra High-Purity

Miniature weld fitting collets, tool mounting side plates and clamping jaws are made of nickel plated tool steel and each hardened for wear and toughness. These are just some of the standards that you have come to expect from MK, the leader in orbital welding systems

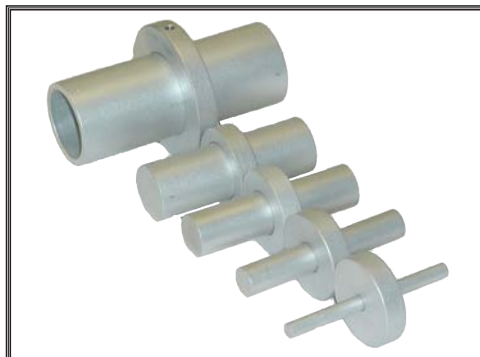

Locating Mandrels

Locating Mandrels are used for precise and repeatable tube and welding fitting positioning and alignment

Offset Tungsten Layout Configurations

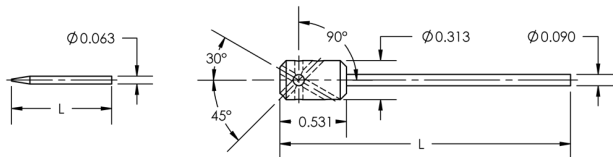

T
(TUNGSTEN
P/N: 635-063-SERIES)

X
(TUNGSTEN EXTENDER ASSEMBLY
P/N: 002-0770)

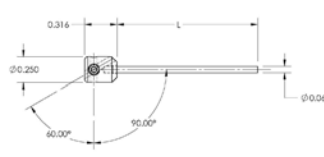

H - 60/90
(TUNGSTEN HOLDER
ASSEMBLY 60 & 90 DEG.
P/N 002-0771)

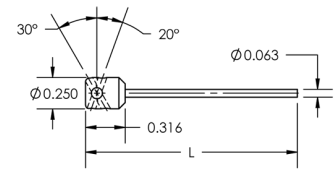

H-20/30
(TUNGSTEN HOLDER
ASSEMBLY 20 & 30 DEG
P/N: 002-0772)

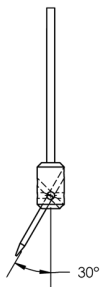

T

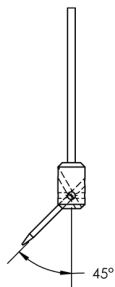

T + X

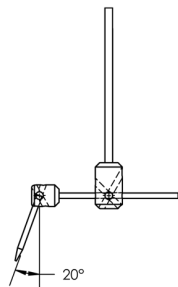

T + X + H-20/30

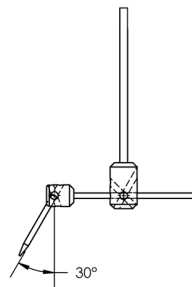

T + X + H-20/30

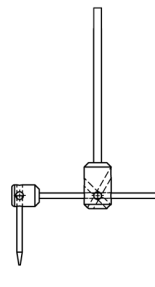

T + X + H-90

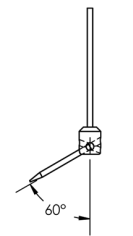

T + H-20/30

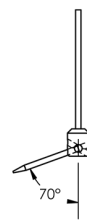

T + H-20/30

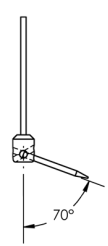
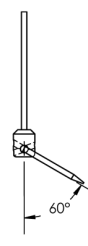
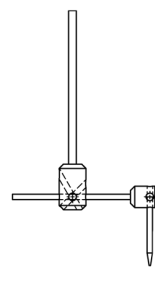
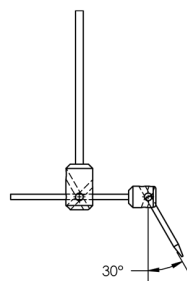
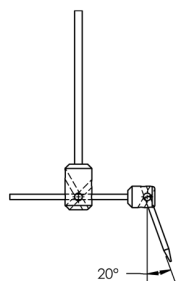
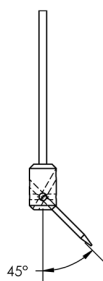
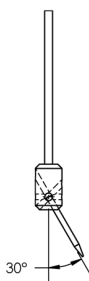

Tungsten and Collets

Pricing also available at www.mkproducts.com

Refer to tables below for Copperhead®, DiamondBack® and MiniMicro® flush and extended collets. Simply choose your weldhead model, tube OD, for collet and precut tungsten part numbers

Need a custom size, or more information? Contact our customer service team to discuss your application!

Note: A set of collets is defined as top and bottom halves for each side of the weldhead. Typically, 2 sets are required per weldhead.

Mini Micro (P/N 4000)				
OD	Flush Collets <i>Part Number</i>	Extended Collets <i>Part Number</i>	Tungsten <i>Part Number (.040dia)</i>	Tungsten <i>Part Number (.063 dia)</i>
1/8	623-4000-0.125	624-4000-0.125	635-040-0.468	635-063-0.468
3/16	623-4000-0.625	624-4000-0.625	635-040-0.437	635-063-0.437
1/4	623-4000-0.250	624-4000-0.250	635-040-0.406	635-063-0.406
5/16	623-4000-0.313	624-4000-0.313	635-040-0.377	635-063-0.377
7/16	623-4000-0.109	624-4000-0.109	635-040-0.312	635-063-0.312
3/8	623-4000-0.375	624-4000-0.375	635-040-0.343	635-063-0.343
1/2	623-4000-0.500	624-4000-0.500	635-040-0.281	635-063-0.281
4MM	623-4000-4.0MM	624-4000-4.0MM	635-040-0.452	635-063-0.452
6MM	623-4000-6.0MM	624-4000-6.0MM	635-040-0.413	635-063-0.413
8MM	623-4000-8.0MM	624-4000-8.0MM	635-040-0.377	635-063-0.377
10MM	623-4000-10.0MM	624-4000-10.0MM	635-040-0.339	635-063-0.339
12MM	623-4000-12.0MM	624-4000-12.0MM	635-040-0.295	635-063-0.295

Tungsten sold in packs of 10

5001 Weldheads					
OD	Flush Collets <i>Part Number</i>	Extended Collets <i>Part Number</i>	Tungsten <i>Part Number (.040 dia)</i>	Tungsten <i>Part Number (.063 dia)</i>	Tungsten <i>Part Number (.093 dia)</i>
1/8	623-0110-0.125	624-0110-0.125	635-040-0.984	635-063-0.984	635-093-0.984
1/4	623-0110-0.250	624-0110-0.250	635-040-0.922	635-063-0.922	635-093-0.922
3/8	623-0110-0.375	624-0110-0.375	635-040-0.859	635-063-0.859	635-093-0.859
1/2	623-0110-0.500	624-0110-0.500	635-040-0.797	635-063-0.797	635-093-0.797
9/16	623-0110-0.563	624-0110-0.563	635-040-0.766	635-063-0.766	635-093-0.766
5/8	623-0110-0.625	624-0110-0.625	635-040-0.734	635-063-0.734	635-093-0.734
3/4	623-0110-0.750	624-0110-0.750	635-040-0.672	635-063-0.672	635-093-0.672
7/8	623-0110-0.875	624-0110-0.875	635-040-0.609	635-063-0.609	635-093-0.609
1	623-0110-1.000	624-0110-1.000	635-040-0.547	635-063-0.547	635-093-0.547
1/8 NP	623-0110-1/8NP	624-0110-1/8NP	635-040-0.844	635-063-0.844	635-093-0.844
1/4 NP	623-0110-1/4NP	624-0110-1/4NP	635-040-0.766	635-063-0.766	635-093-0.766
3/8 NP	623-0110-3/8NP	624-0110-3/8NP	635-040-0.703	635-063-0.703	635-093-0.703
1/2 NP	623-0110-1/2NP	624-0110-1/2NP	635-040-0.625	635-063-0.625	635-093-0.625

Tungsten sold in packs of 10

For a complete price list of all MK available tungsten and collets, visit www.mkproducts.com

5001 Weldheads					
OD	Flush Collets <i>Part Number</i>	Extended Collets <i>Part Number</i>	Tungsten <i>Part Number (.040 dia)</i>	Tungsten <i>Part Number (.063 dia)</i>	Tungsten <i>Part Number (.093 dia)</i>
6.0 MM	623-0110-6.0MM	624-0110-6.0MM	635-040-0.922	635-063-0.922	635-093-0.922
7.0 MM	623-0110-7.0MM	624-0110-7.0MM	635-040-0.906	635-063-0.906	635-093-0.906
8.0 MM	623-0110-8.0MM	624-0110-8.0MM	635-040-0.891	635-063-0.891	635-093-0.891
10.0 MM	623-0110-10.0MM	624-0110-10.0MM	635-040-0.844	635-063-0.844	635-093-0.844
10.2 MM	623-0110-10.2MM	624-0110-10.2MM	635-040-0.844	635-063-0.844	635-093-0.844
12.0 MM	623-0110-12.0MM	624-0110-12.0MM	635-040-0.813	635-063-0.813	635-093-0.813
13.5 MM	623-0110-13.5MM	624-0110-13.5MM	635-040-0.781	635-063-0.781	635-093-0.781
14.0 MM	623-0110-14.0MM	624-0110-14.0MM	635-040-0.766	635-063-0.766	635-093-0.766
15.0 MM	623-0110-15.0MM	624-0110-15.0MM	635-040-0.750	635-063-0.750	635-093-0.750
16.0 MM	623-0110-16.0MM	624-0110-16.0MM	635-040-0.734	635-063-0.734	635-093-0.734
16.5 MM	623-0110-16.5MM	624-0110-16.5MM	635-040-0.719	635-063-0.719	635-093-0.719
17.2 MM	623-0110-17.2MM	624-0110-17.2MM	635-040-0.703	635-063-0.703	635-093-0.703
18.0 MM	623-0110-18.0MM	624-0110-18.0MM	635-040-0.688	635-063-0.688	635-093-0.688
19.1 MM	623-0110-19.1MM	624-0110-19.1MM	635-040-0.672	635-063-0.672	635-093-0.672
20.0 MM	623-0110-20.0MM	624-0110-20.0MM	635-040-0.656	635-063-0.656	635-093-0.656
21.3 MM	623-0110-21.3MM	624-0110-21.3MM	635-040-0.625	635-063-0.625	635-093-0.625
22.0 MM	623-0110-22.0MM	624-0110-22.0MM	635-040-0.609	635-063-0.609	635-093-0.609
23.0 MM	623-0110-23.0MM	624-0110-23.0MM	635-040-0.594	635-063-0.594	635-093-0.594
25.0 MM	623-0110-25.0MM	624-0110-25.0MM	635-040-0.547	635-063-0.547	635-093-0.547
5001 Collet Blanks	623-0151	624-0161			

Tungsten sold in packs of 10

5002 Weldheads				
OD	Flush Collets <i>Part Number</i>	Extended Collets <i>Part Number</i>	Tungsten <i>Part Number (.063 dia)</i>	Tungsten <i>Part Number (.093 dia)</i>
1/4	623-0210-0.250	624-0210-0.250	635-063-1.609	635-093-1.609
3/8	623-0210-0.375	624-0210-0.375	635-063-1.547	635-093-1.547
1/2	623-0210-0.500	624-0210-0.500	635-063-1.484	635-093-1.484
5/8	623-0210-0.625	624-0210-0.625	635-063-1.422	635-093-1.422
3/4	623-0210-0.750	624-0210-0.750	635-063-1.359	635-093-1.359
7/8	623-0210-0.875	624-0210-0.875	635-063-1.302	635-093-1.302
1	623-0210-1.000	624-0210-1.000	635-063-1.238	635-093-1.238
1-1/8	623-0210-1.125	624-0210-1.125	635-063-1.171	635-093-1.171
1-1/4	623-0210-1.250	624-0210-1.250	635-063-1.102	635-093-1.102
1-3/8	623-0210-1.375	624-0210-1.375	635-063-1.047	635-093-1.047

Tungsten sold in packs of 10

For a complete price list of all MK available tungsten and collets, visit www.mkproducts.com

5002 Weldheads				
OD	Flush Collets <i>Part Number</i>	Extended Collets <i>Part Number</i>	Tungsten <i>Part Number (.063 dia)</i>	Tungsten <i>Part Number (.093 dia)</i>
1-1/2	623-0210-1.500	624-0210-1.500	635-063-0.984	635-093-0.984
1-3/4	623-0210-1.750	624-0210-1.750	635-063-0.859	635-093-0.859
1-7/8	623-0210-1.875	624-0210-1.875	635-063-0.797	635-093-0.797
2	623-0210-2.000	624-0210-2.000	635-063-0.734	635-093-0.734
1/8 NP	623-0210-1/8NP	624-0210-1/8NP	635-063-1.531	635-093-1.531
1/4 NP	623-0210-1/4NP	624-0210-1/4NP	635-063-1.453	635-093-1.453
3/8 NP	623-0210-3/8NP	624-0210-3/8NP	635-063-1.391	635-093-1.391
1/2 NP	623-0210-1/2NP	624-0210-1/2NP	635-063-1.316	635-093-1.316
3/4 NP	623-0210-3/4NP	624-0210-3/4NP	635-063-1.203	635-093-1.203
1 NP	623-0210-1NP	624-0210-1NP	635-063-1.073	635-093-1.073
1-1/4 NP	623-0210-1-1/4NP	624-0210-1-1/4NP	635-063-0.891	635-093-0.891
1-1/2 NP	623-0210-1-1/2NP	624-0210-1-1/2NP	635-063-0.781	635-093-0.781
5.1 MM	623-0210-5.1MM	624-0210-5.1MM	635-063-1.625	635-093-1.625
6.0 MM	623-0210-6.0MM	624-0210-6.0MM	635-063-1.625	635-093-1.625
6.6 MM	623-0210-6.6MM	624-0210-6.6MM	635-063-1.609	635-093-1.609
8.0 MM	623-0210-8.0MM	624-0210-8.0MM	635-063-1.578	635-093-1.578
10.0 MM	623-0210-10.0MM	624-0210-10.0MM	635-063-1.531	635-093-1.531
10.2 MM	623-0210-10.2MM	624-0210-10.2MM	635-063-1.531	635-093-1.531
12.0 MM	623-0210-12.0MM	624-0210-12.0MM	635-063-1.500	635-093-1.500
13.5 MM	623-0210-13.5MM	624-0210-13.5MM	635-063-1.469	635-093-1.469
14.0 MM	623-0210-14.0MM	624-0210-14.0MM	635-063-1.453	635-093-1.453
15.0 MM	623-0210-15.0MM	624-0210-15.0MM	635-063-1.438	635-093-1.438
16.0 MM	623-0210-16.0MM	624-0210-16.0MM	635-063-1.422	635-093-1.422
17.2 MM	623-0210-17.2MM	624-0210-17.2MM	635-063-1.391	635-093-1.391
18.0 MM	623-0210-18.0MM	624-0210-18.0MM	635-063-1.386	635-093-1.386
20.0 MM	623-0210-20.0MM	624-0210-20.0MM	635-063-1.343	635-093-1.343
21.2 MM	623-0210-21.2MM	624-0210-21.2MM	635-063-1.316	635-093-1.316
21.3 MM	623-0210-21.3MM	624-0210-21.3MM	635-063-1.316	635-093-1.316
22.4 MM	623-0210-22.4MM	624-0210-22.4MM	635-063-1.295	635-093-1.295
23.0 MM	623-0210-23.0MM	624-0210-23.0MM	635-063-1.277	635-093-1.277
25.0 MM	623-0210-25.0MM	624-0210-25.0MM	635-063-1.238	635-093-1.238
26.0 MM	623-0210-26.0MM	624-0210-26.0MM	635-063-1.228	635-093-1.228
26.9 MM	623-0210-26.9MM	624-0210-26.9MM	635-063-1.203	635-093-1.203
28.0 MM	623-0210-28.0MM	624-0210-28.0MM	635-063-1.187	635-093-1.187
30.0 MM	623-0210-30.0MM	624-0210-30.0MM	635-063-1.136	635-093-1.136
32.0 MM	623-0210-32.0MM	624-0210-32.0MM	635-063-1.102	635-093-1.102
33.7 MM	623-0210-33.7MM	624-0210-33.7MM	635-063-1.073	635-093-1.073

For a complete price list of all MK available tungsten and collets, visit www.mkproducts.com

5002 Weldheads				
OD	Flush Collets <i>Part Number</i>	Extended Collets <i>Part Number</i>	Tungsten <i>Part Number (.063 dia)</i>	Tungsten <i>Part Number (.093dia)</i>
35.0 MM	623-0210-35.0MM	624-0210-35.0MM	635-063-1.047	635-093-1.047
36.0 MM	623-0210-36.0MM	624-0210-36.0MM	635-063-1.020	635-093-1.020
36.5 MM	623-0210-36.5MM	624-0210-36.5MM	635-063-1.020	635-093-1.020
38.0 MM	623-0210-38.0MM	624-0210-38.0MM	635-063-0.984	635-093-0.984
40.0 MM	623-0210-40.0MM	624-0210-40.0MM	635-063-0.938	635-093-0.938
42.4 MM	623-0210-42.4MM	624-0210-42.4MM	635-063-0.891	635-093-0.891
43.0 MM	623-0210-43.0MM	624-0210-43.0MM	635-063-0.891	635-093-0.891
44.0 MM	623-0210-44.0MM	624-0210-44.0MM	635-063-0.859	635-093-0.859
44.5 MM	623-0210-44.5MM	624-0210-44.5MM	635-063-0.859	635-093-0.859
45.1 MM	623-0210-45.1MM	624-0210-45.1MM	635-063-0.844	635-093-0.844
48.3 MM	623-0210-48.3MM	624-0210-48.3MM	635-063-0.781	635-093-0.781
5002- Collet Blank	623-0152	624-0162		

Tungsten sold in packs of 10

5003 Weldheads				
OD	Flush Collets <i>Part Number</i>	Extended Collets <i>Part Number</i>	Tungsten <i>Part Number (.063 dia)</i>	Tungsten <i>Part Number (.093 dia)</i>
1/2	623-0310-0.500	624-0310-0.500	635-063-1.891	635-093-1.891
5/8	623-0310-0.625	624-0310-0.625	635-063-1.828	635-093-1.828
3/4	623-0310-0.750	624-0310-0.750	635-063-1.766	635-093-1.766
7/8	623-0310-0.875	624-0310-0.875	635-063-1.703	635-093-1.703
1	623-0310-1.000	624-0310-1.000	635-063-1.641	635-093-1.641
1-1/8	623-0310-1.125	624-0310-1.125	635-063-1.578	635-093-1.578
1-1/4	623-0310-1.250	624-0310-1.250	635-063-1.516	635-093-1.516
1-3/8	623-0310-1.375	624-0310-1.375	635-063-1.453	635-093-1.453
1-1/2	623-0310-1.500	624-0310-1.500	635-063-1.391	635-093-1.391
1-5/8	623-0310-1.625	624-0310-1.625	635-063-1.332	635-093-1.332
1-3/4	623-0310-1.750	624-0310-1.750	635-063-1.266	635-093-1.266
1-7/8	623-0310-1.875	624-0310-1.875	635-063-1.203	635-093-1.203
2	623-0310-2.000	624-0310-2.000	635-063-1.136	635-093-1.136
2-1/4	623-0310-2.250	624-0310-2.250	635-063-1.020	635-093-1.020
2-1/2	623-0310-2.500	624-0310-2.500	635-063-0.891	635-093-0.891
2-3/4	623-0310-2.750	624-0310-2.750	635-063-0.766	635-093-0.766
3	623-0310-3.000	624-0310-3.000	635-063-0.641	635-093-0.641

Tungsten sold in packs of 10

For a complete price list of all MK available tungsten and collets, visit www.mkproducts.com

5003 Weldheads				
OD	Flush Collets <i>Part Number</i>	Extended Collets <i>Part Number</i>	Tungsten <i>Part Number (.063 dia)</i>	Tungsten <i>Part Number (.093 dia)</i>
1/4 NP	623-0310-1/4NP	624-0310-1/4NP	635-063-1.859	635-093-1.859
3/8 NP	623-0310-3/8NP	624-0310-3/8NP	635-063-1.797	635-093-1.797
1/2 NP	623-0310-1/2NP	624-0310-1/2NP	635-063-1.719	635-093-1.719
3/4 NP	623-0310-3/4NP	624-0310-3/4NP	635-063-1.609	635-093-1.609
1 NP	623-0310-1NP	624-0310-1NP	635-063-1.469	635-093-1.469
1-1/4 NP	623-0310-1-1/4NP	624-0310-1-1/4NP	635-063-1.302	635-093-1.302
1-1/2 NP	623-0310-1-1/2NP	624-0310-1-1/2NP	635-063-1.187	635-093-1.187
2 NP	623-0310-2NP	624-0310-2NP	635-063-0.953	635-093-0.953
2-1/2 NP	623-0310-2-1/2NP	624-0310-2-1/2NP	635-063-0.688	635-093-0.688
13.5 MM	623-0310-13.5MM	624-0310-13.5MM	635-063-1.875	635-093-1.875
14.0 MM	623-0310-14.0MM	624-0310-14.0MM	635-063-1.859	635-093-1.859
15.0 MM	623-0310-15.0MM	624-0310-15.0MM	635-063-1.843	635-093-1.843
16.0 MM	623-0310-16.0MM	624-0310-16.0MM	635-063-1.828	635-093-1.828
17.2 MM	623-0310-17.2MM	624-0310-17.2MM	635-063-1.797	635-093-1.797
18.0 MM	623-0310-18.0MM	624-0310-18.0MM	635-063-1.781	635-093-1.781
20.0 MM	623-0310-20.0MM	624-0310-20.0MM	635-063-1.750	635-093-1.750
21.3 MM	623-0310-21.3MM	624-0310-21.3MM	635-063-1.719	635-093-1.719
23.0 MM	623-0310-23.0MM	624-0310-23.0MM	635-063-1.688	635-093-1.688
26.0 MM	623-0310-26.0MM	624-0310-26.0MM	635-063-1.625	635-093-1.625
26.9 MM	623-0310-26.9MM	624-0310-26.9MM	635-063-1.609	635-093-1.609
28.0 MM	623-0310-28.0MM	624-0310-28.0MM	635-063-1.594	635-093-1.594
30.0 MM	623-0310-30.0MM	624-0310-30.0MM	635-063-1.547	635-093-1.547
32.0 MM	623-0310-32.0MM	624-0310-32.0MM	635-063-1.516	635-093-1.516
33.4 MM	623-0310-33.4MM	624-0310-33.4MM	635-063-1.484	635-093-1.484
33.7 MM	623-0310-33.7MM	624-0310-33.7MM	635-063-1.469	635-093-1.469
35.0 MM	623-0310-35.0MM	624-0310-35.0MM	635-063-1.453	635-093-1.453
38.0 MM	623-0310-38.0MM	624-0310-38.0MM	635-063-1.391	635-093-1.391
40.0 MM	623-0310-40.0MM	624-0310-40.0MM	635-063-1.359	635-093-1.359
42.4 MM	623-0310-42.4MM	624-0310-42.4MM	635-063-1.302	635-093-1.302
43.0 MM	623-0310-43.0MM	624-0310-43.0MM	635-063-1.295	635-093-1.295
44.0 MM	623-0310-44.0MM	624-0310-44.0MM	635-063-1.277	635-093-1.277
44.5 MM	623-0310-44.5MM	624-0310-44.5MM	635-063-1.266	635-093-1.266
48.3 MM	623-0310-48.3MM	624-0310-48.3MM	635-063-1.187	635-093-1.187
51.0 MM	623-0310-51.0MM	624-0310-51.0MM	635-063-1.136	635-093-1.136
53.0 MM	623-0310-53.0MM	624-0310-53.0MM	635-063-1.095	635-093-1.095
54.0 MM	623-0310-54.0MM	624-0310-54.0MM	635-063-1.073	635-093-1.073
57.0 MM	623-0310-57.0MM	624-0310-57.0MM	635-063-1.020	635-093-1.020
5003- Blank Collets	623-0153	624-0163		

Tungsten sold in packs of 10

For a complete price list of all MK available tungsten and collets, visit www.mkproducts.com

5006 Weldheads				
OD	Flush Collets <i>Part Number</i>	Extended Collets <i>Part Number</i>	Tungsten <i>Part Number (.063 dia)</i>	Tungsten <i>Part Number (.093 dia)</i>
2	623-5006-2.000	624-5006-2.000	635-063-3.339	635-093-3.339
2-1/2	623-5006-2.500	624-5006-2.500	635-063-3.089	635-093-3.089
3	623-5006-3.000	624-5006-3.000	635-063-2.828	635-093-2.828
3-1/2	623-5006-3.500	624-5006-3.500	635-063-2.578	635-093-2.578
4	623-5006-4.000	624-5006-4.000	635-063-2.328	635-093-2.328
4-1/2	623-5006-4.500	624-5006-4.500	635-063-2.086	635-093-2.086
5	623-5006-5.000	624-5006-5.000	635-063-1.828	635-093-1.828
5-1/2	623-5006-5.500	624-5006-5.500	635-063-1.578	635-093-1.578
6	623-5006-6.000	624-5006-6.000	635-063-1.332	635-093-1.332
2 NP	623-5006-2NP	624-5006-2NP	635-063-3.147	635-093-3.147
2-1/2 NP	623-5006-2-1/2NP	624-5006-2-1/2NP	635-063-2.890	635-093-2.890
3 NP	623-5006-3NP	624-5006-3NP	635-063-2.578	635-093-2.578
3-1/2 NP	623-5006-3-1/2NP	624-5006-3-1/2NP	635-063-2.328	635-093-2.328
4 NP	623-5006-4NP	624-5006-4NP	635-063-2.067	635-093-2.067
5 NP	623-5006-5NP	624-5006-5NP	635-063-1.531	635-093-1.531
60.0 MM	623-5006-60.0MM	624-5006-60.0MM	635-063-3.147	635-093-3.147
72.0 MM	623-5006-72.0MM	624-5006-72.0MM	635-063-2.890	635-093-2.890
78.8 MM	623-5006-78.8MM	624-5006-78.8MM	635-063-2.781	635-093-2.781
114.0 MM	623-5006-114.0MM	624-5006-114.0MM	635-063-2.086	635-093-2.086
115.0 MM	623-5006-115.0MM	624-5006-115.0MM	635-063-2.067	635-093-2.067
5006 Collet Blank	623-5006	624-5006		

Tungsten sold in packs of 10

For a complete price list of all MK available tungsten and collets, visit www.mkproducts.com

NEED CUSTOM Tungsten & Collets?

Custom sizes available!

Consult with our customer service team at



1-800-787-9707



sales@mkprod.com



**Building the World
MADE IN AMERICA**



Stay In Touch!

