



**KISTLER**  
CUTTING AND WELDING TECHNIQUES



THE SPECIALIST IN ENGINEERING AND MANUFACTURING  
OF WELDING AND CUTTING SYSTEMS

# CONTENTS

<b>U RANGE</b> PIPE ROTATORS WITH CLAMPING SYSTEM .....	4
<b>BR RANGE</b> TURNING ROLLS .....	6
<b>CR RANGE</b> CONVENTIONAL ROTATORS .....	7
<b>BRS RANGE</b> TURNING ROLLS .....	8
<b>RS RANGE</b> TURNING ROLLS OF THE RS RANGE .....	9
<b>SAR RANGE</b> SELF-ALIGNING ROTATORS .....	10
<b>R RANGE</b> WELDING POSITIONERS .....	11
<b>VP RANGE</b> CONVENTIONAL POSITIONERS .....	12
<b>VP/A RANGE</b> ROTILING WELDING POSITIONERS .....	13
<b>HP RANGE</b> POSITIONERS .....	14
<b>L RANGE</b> POSITIONERS .....	15
<b>H RANGE</b> TURNTABLES .....	16
<b>TT RANGE</b> TURNTABLES .....	17
<b>QCS RANGE</b> QUICK CLAMPING SYSTEM .....	18
<b>MC RANGE</b> MANUAL CHUCKS .....	19
<b>GR RANGE</b> OSCILLATORS FOR WELDING .....	20
<b>SCM RANGE</b> PIPE CUTTING MACHINES .....	21

<b>RSM RANGE</b> CNC-CONTROLLED PIPE CUTTING MACHINE .....	25
<b>RMB/TRMB RANGE</b> COLUMN & BOOM MANIPULATOR .....	26
<b>RC/TRC RANGE</b> HEAVY DUTY COLUMN & BOOM MANIPULATOR .....	27
<b>TRC/F RANGE</b> COLUMN & FIXED BOOM MANIPULATOR .....	28
<b>LBL RANGE</b> H BEAM WELDING LINES .....	29
<b>VBL RANGE</b> H BEAM WELDING LINES .....	30
<b>HSW RANGE</b> SEAMWELDING MACHINE .....	31
<b>SUBMERGED ARC WELDING HEADS</b> .....	32
<b>FLUX FEED AND RECOVERY SYSTEMS</b> .....	33
<b>WIRE MASTER</b> .....	36
<b>OAWC RANGE</b> WELDING CAMERA .....	37
<b>TURNKEY SYSTEMS</b> .....	38
<b>TEAM</b> .....	40

# U RANGE PIPE ROTATORS WITH CLAMPING SYSTEM

## APPLICATIONS

For clamping, rotation and tilting of pipes with round profiles in manual or automatic welding, mainly in the field of pipe construction (prefabrication and assembly on site) as well as in the manufacture of plant.

Apart from being extremely economical (single handed operation, no interruptions due to repeated turning of the pipe to be welded), this machine also offers improvements in quality – there are no interruptions in the joint and a continually precise horizontal position of the pipe is maintained.

## DESCRIPTION

The electric control as well as the tilting drive are located in the frame. Tilting is carried out manually (U 150 and U 500) or motorized (U 1000, optional U 500) the tilting angle is approx. 135°. The tilting section consists of drive and roller box, holding column, clamping arm and pressure roller. This machine is also available as a non tilting version (designation: U 150H, U 500H, U 1000H). In general, drives and electric controls of the U-series are protected in the frame or in a control panel.

## ELECTRIC CONTROL

Rotary speed and direction are set at the front of the machine which is switched on and off by a remote foot switch.

Further options of electric control:

a) Separate foot operated control unit (see illustration U 500, photo on this page). Switching on and off and changing the direction of rotation takes place by a foot switch, the rotary speed is adjusted by a foot control roller.

b) Switching on and off as well as changing the direction of rotation is carried out from the welder's helmet or shield. The rotary speed is set at the machine.

c) Turning direction and turning speed are set on a remote hand pendant.



MODEL	SIZE OF PIPE mm/inches	max. LOAD kg/lbs	ROTARY SPEED cm/min and inches/min
U 150	20 - 200 / 1 - 8	300/660	0 - 120 / 0 - 50
U 150H	20 - 200 / 1 - 8	300/660	0 - 120 / 0 - 50
U 500	20 - 400 / 1 - 16	1000/2200	0 - 100 / 0 - 40
U 500 H	20 - 400 / 1 - 16	1000/2200	0 - 100 / 0 - 40
U 1000	50 - 800 / 2 - 32	2000/4400	0 - 70 / 0 - 28
U 1000 H	50 - 800 / 2 - 32	2000/4400	0 - 70 / 0 - 28

The U...H models have no tilting mechanism, but apart from that they correspond exactly to the U models.

### Some examples for application

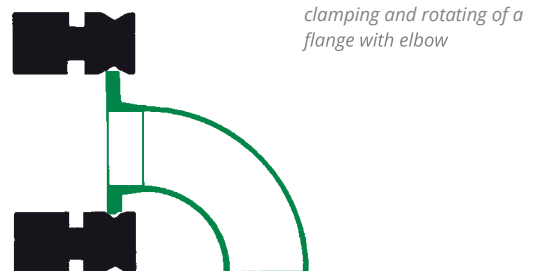
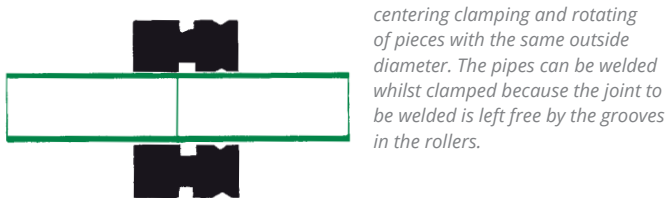
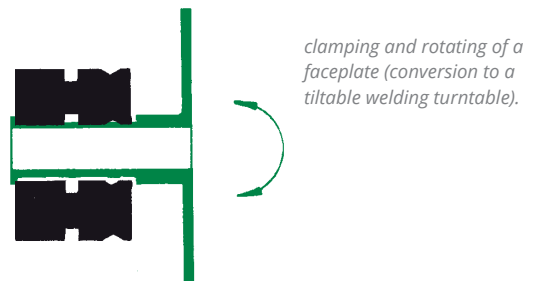
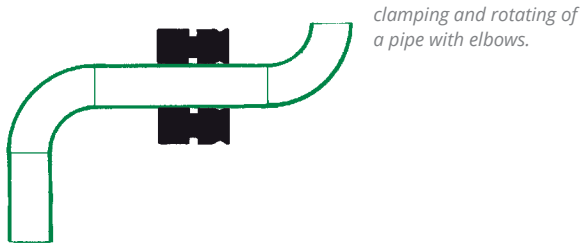

# BR RANGE TURNING ROLLS

## DESCRIPTION

The BR turning rolls are used for turning of work pieces, mainly for welding. A set of turning rolls consists of one drive and one idler unit, the load capacity is calculated for this set-up. Roller distance to accommodate various diameters is set manually. Standard rollers are equipped with rubber wheels, optional wheel surface can be

polyurethane or steel. Standard turning speed is adjustable from 0 up to 1500 mm/min. All models can be equipped with manual or motorized bogies (option). Machines can be equipped with various controls e.g. foot switch, hand pendant or control within welder's shield.

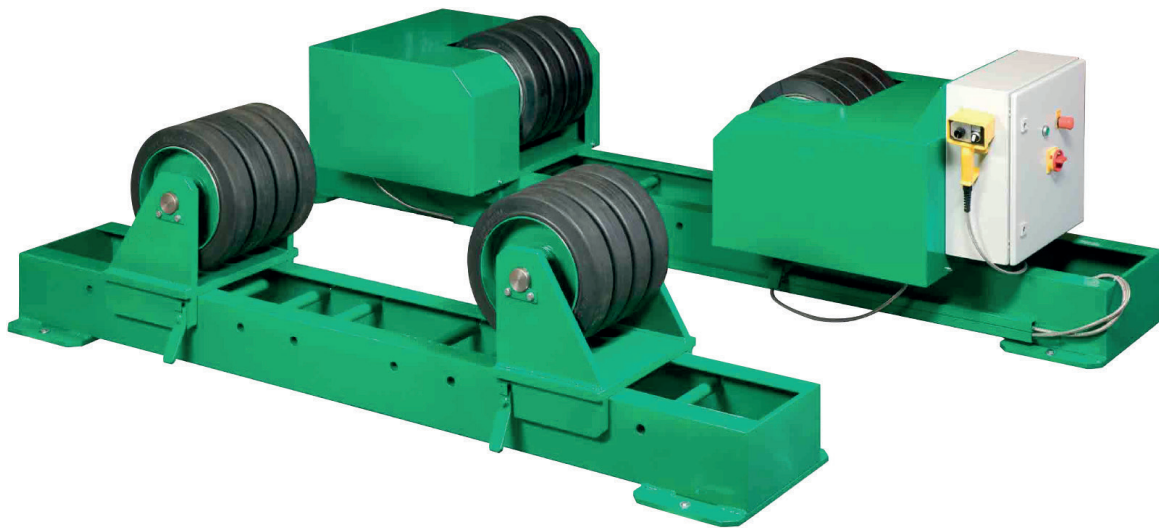

MODEL	CAPACITY kg/lbs	WORKPIECE DIAMETER		REMARKS
		min. (mm/ inch)	max. (mm/ inch)	
BR 1000	1000/2200	70/3	1500/59	
BR 2000	2000/4400	80/3	2500/89	
BR 5000	5000/11 000	200/8	3000/118	Double drive optional
BR 10 000	10 000/22 000	300/12	4000/157	Double drive
BR 20 000	20 000/44 000	300/12	4000/157	Double drive
BR 30 000	30 000/66 100	300	4000/157	Double drive

# CR RANGE CONVENTIONAL ROTATORS

## DESCRIPTION

The Conventional Rotator is mainly of interest to the smaller vessel manufacturer who can tolerate the time taken to adjust the supporting wheels across the frame when changing vessel diameters.

The supporting wheels of the Conventional Rotator are manually moved across the frame to suit the diameters of the vessel or manually through leadscrew adjustment. Conventional Rotators are supplied in capacities from 1 ton to 800 tons using 1 Drive and 1 Idler.

All Kistler Conventional Rotators have precision machined base frames. On the top face are the machine slideways for the wheel brackets and have high accuracy location holes for positioning the wheel brackets across the frame. The lower face is accurately machined to enable the Rotator section alignment to be achieved with maximum efficiency. The load capacity and the effect of shock loading are taken into account at the design stage.

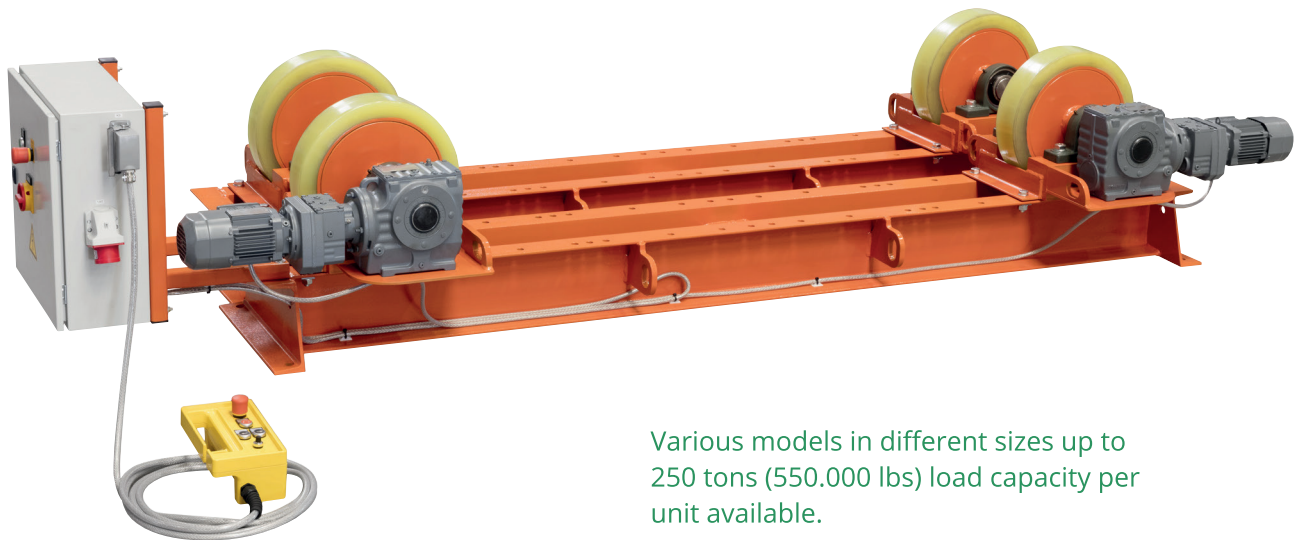

Various models in different sizes up to 250 tons (550.000 lbs) load capacity per unit available.

# BRS RANGE TURNING ROLLS

## DESCRIPTION

The BRS turning rolls comes with a standard double drive (both wheels in the drive unit are driven) and are used for work pieces with unbalanced weights.

A set of turning rolls consists of one idler and one drive unit, load capacity is calculated for this set-up.



TYPE	CAPACITY kg/lbs	WORKPIECE DIAMETER		REMARKS
		min. (mm/inch)	max. (mm/inch)	
BRS 1000	1000/2200	70/3	1500/59	Double drive
BRS 2000	2000/4400	80/3	2500/98	Double drive
BRS 5000	5000/11000	200/8	3000/118	Double drive



# RS RANGE

## TURNING ROLLS OF THE RS RANGE

### DESCRIPTION

The RS range turning rolls are used for turning of work pieces, mainly for welding. A set of turning rolls consists of one drive and one idler unit, the load capacity is calculated for this set-up. Roller distance to accommodate various diameters is set manually. Standard rollers are equipped with rubber, Polyurethane or Vulkollan wheels, opti-

onal wheel surface steel is available on request. Standard turning speed is adjustable from 0 mm/min up to 1500 mm/min. All models can be equipped with manual or motorized bogies (option). Machines can be equipped with various controls e.g. foot switch, hand pendant or control within welder's shield.

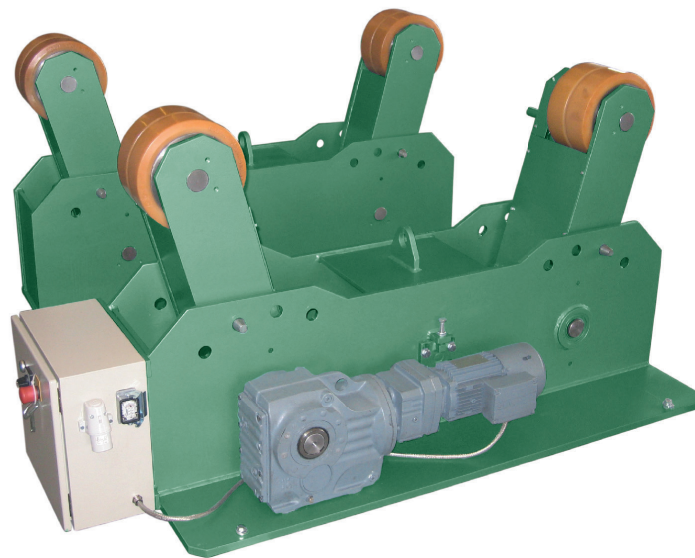

MODEL	CAPACITY	MIN.	MAX.	HEIGHT H1	HEIGHT H2	LENGTH L	WIDTH IDLER B1	WIDTH DRIVE B2	WHEEL-DIA D	WHEEL LENGTH LR	WHEEL MATERIAL	TURNING SPEED	WEIGHT DRIVE	WEIGHT IDLER
	kg/lbs											cm/min. inches/min		
RS 3	3000/6600	100	2500	610	665	990	300	500	250	120	Rubber	6 - 150/2 - 59	200	200
RS 6	6000/13 200	100	3000	650	700	1350	450	700	250	160	Rubber	6 - 150/2 - 59	300	300
RS 10	10 000/22 000	200	3500	760	800	1500	375	565	250	160	Vulkollan	6 - 150/2 - 59	400	400
RS 15	15 000/33 000	200	3500	750	800	1500	500	800	250	240	Vulkollan	6 - 150/2 - 59	530	530
RS 20	20 000/44 100	400	4000	800	900	1700	700	1000	250	320	Vulkollan	6 - 150/2 - 59	700	700
RS 30	30 000/66 100	500	4500	900	1000	1900	750	1150	250	360	Vulkollan	6 - 150/2 - 59	1000	1000

# SAR RANGE SELF-ALIGNING ROTATORS

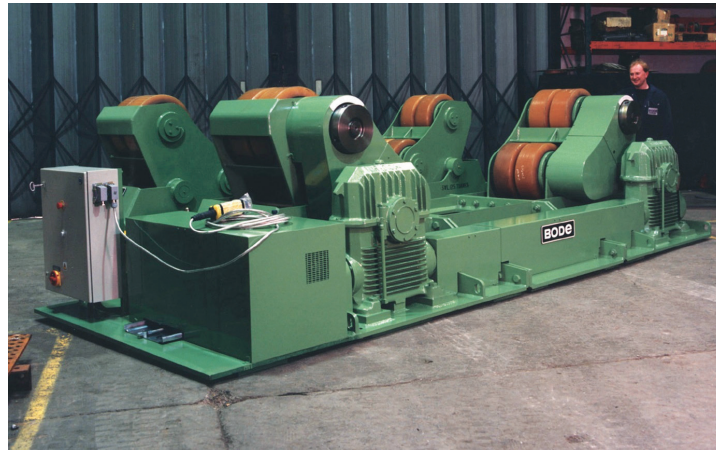

## DESCRIPTION

Kistler's Traversing Self-Aligning Rotators follow the well established reputation of their static counter-parts for ease of use and reliability.

Like their counter-parts they provide an economical and practical platform for all cylindrical vessel rotating problems. Their patented and unique designs allow the rollers to automatically align themselves to any workpiece, without any form of manual adjustment and irrespective of irregularity in the shape of the circular workpiece.

This exceptional facility not only saves time, but in ensuring that the item being worked on remains central to the rotator frames, eliminates any need for welding head adjustment.

The Traversing Self-Aligning Rotator range are all bogie mounted to carry vessels of various lengths, and to allow for traversing, in addition to rotation at the work site. The 'low loading' bogie design integral to the rotator construction ensures that unlike standard bogies, their closeness to the ground eliminates the risk of excess vessel loading heights.

As is to be expected of Kistler machinery, all Traversing Self-Aligning Rotators are built to the highest standards with quality materials and components:

- Robust, all-steel construction
- Inverter controlled traversing and rotation at welding speeds.
- All rollers of the Drive Section positively driven.
- Clutches incorporated in top rollers of the Drive Section to prevent damage to transmission during loading.
- On unloading easy-pivot roller brackets operate in reverse, moving to their resting position, ready to take next piece.
- Idler Section can incorporate manual or electric anti-creep feature to restrict vessel 'creep' to +/- 1 mm.

Various models in different sizes up to 300 tons (660.000 lbs) load capacity per section available.

# R RANGE WELDING POSITIONERS

## DESCRIPTION

On all models, the rotation speed is infinitely variable (see data sheet). The drivers for turning of the faceplate and tilting as well as the electrical control are located in protective housings. On all models, the tilting angle is 135° infinitely variable from the horizontal faceplate to the 45° negative tilted faceplate.



Modell R 100



Modell R 500

## ELECTRICAL CONTROL

On the models R 50, R 100 and R 300, the setting of the forward-stop-reverse rotation as well as the speed of the rotation are set at the front of the machine which is switched on and off by a remote foot switch. As an option, these models come with a remote control (hand pendant, foot control until or control within the welder's shield). With the models R 500 - R 10000, a remote control for forward-stop-reverse, up-stop-down tilt as well as a potentiometer for the rotation speed is included as a standard. The user can choose between a hand-pendant, foot control until or control within the welder's shield.



Modell R 300

Various models in different sizes up to 12000 kg (26000 lbs) load capacity per available.

# VP RANGE CONVENTIONAL POSITIONERS



## DESCRIPTION

With decades of engineering expertise and design skills, today's Kistler positioners are second-to-none, handling workpieces from just a couple of hundred kilograms to several hundred tons. Size has never been a problem with Kistler!

Free-standing, robust all steel fabrication, variable speed table rotation, round or square „T slotted“ tables with extension arms on some models, table tilt, steel gears, enclosed electric motors including electro-magnetic brakes, efficient built-in earthing, pendant remote push button controls on many models, and a range of optional extras, all make Kistler Positioners exceptionally valuable pieces of equipment on any production floor. Equally, they represent great value for money.

Contact us today for more information, or to discuss your special positioner needs.



Various models in different sizes up to 100 tons (200,000 lbs) load capacity available.

# VP/A RANGE ROTLING WELDING POSITIONERS



## DESCRIPTION

For the best welds in the shortest possible time, it is necessary to move the workpiece into downhand welding positions.

The Kistler "Rotiling" Positioner provides the quickest means of both rotating and tilting through 360° while allowing maximum access to the workpiece.

Various models in different sizes up to 2500 kg (5500 lbs) load capacity available.

The Machine to incorporate the following features:

- Robust fabricated all steel construction.
- Table shaft carried in timken bearings.
- Fully machined table provided with concentric rings and slots to enable workpieces to be readily secured.
- Self-locking worm gear tilt drive.
- Table rotates and tilts through 360°.
- Workpieces can be loaded easily and quickly – no balancing necessary.
- Variable speed table rotation by inverter, or single speed, through 360°.

# HP RANGE POSITIONERS

## DESCRIPTION

Positioners of the HP-range are used for welding, grinding and positioning purposes. Apart from the turning drive of the faceplate, this range of positioners provides hydraulic tilting of the faceplate and hydraulic lifting.

Infinitely variable workpiece positioning ensures ideal ergonomic and economic working positions.

## TECHNICAL DATA

**Turning drive** Geared AC-motor, controlled by an inverter is driving the face plate over a ball bearing

**Tilting movement** hydraulic

**Height adjustment** hydraulic

**Electrics** 400V, 3PH., 50 Hz



MODEL	NOMINAL LOAD	ROTATING TORQUE	TILTING TORQUE	A = Length	B = Width	D = Faceplate Diameter	H min. = Height	H max. = Height	SPEED
	kg/lbs	Nm	max. Nm	mm/inch	mm/inch	mm/inch	mm/inch	mm/inch	rpm
HP 3000	3000/6600	2000	7500	2000/79	1200/47	1100/43	800/31	1500/59	0 - 1
HP 5000	5000/11 000	5000	10 000	2300/91	1600/63	1200/47	800/31	1500/59	0 - 1
HP 7500	7500/16 500	8000	14 000	2600/102	2000/79	1250/49	1000/39	1700/67	0 - 1
HP 10 000	10 000/22 000	12 000	30 000	3000/118	2000/79	1300/51	1000/39	2000/79	0 - 0,75
HP 15 000	15 000/33 000	15 000	65 000	3000/118	2000/79	1500/59	1200/47	2100/83	0 - 0,75
HP 20 000	20 000/44 000	20 000	100 000	4000/157	2300/91	1700/67	1200/47	2100/83	0 - 0,75
HP 25 000	25 000/55 100	30 000	175 000	4200/165	2500/98	1800/71	1300/51	2300/91	0 - 0,5
HP 30 000	30 000/66 100	40 000	250 000	4200/165	2500/98	2000/79	1300/51	2300/91	0 - 0,5

# L RANGE POSITIONERS

## DESCRIPTION

Positioners of the L-range are used for welding, grinding and positioning purposes.

Apart from the motorized turning drive of the faceplate, this range of positioners provides electric tilting and hydraulic lifting. Infinitely variable work-piece positioning ensures ideal ergonomic and economic working positions.



## TECHNICAL DATA

**Turning drive** Geared AC-motor, controlled by an inverter is driving the face plate via pinion / toothed slewing ring

**Tilting movement** Geared AC-motor, controlled by an inverter via pinion / toothed slewing ring

**Height adjustment** hydraulic

**Electrics** 400V, 3PH., 50 Hz

MODEL	Load capacity	Rotating torque	Max. swing radius	Face-plate tilting axis	Face-plate height	Face-plate diameter	Lifting stroke	Tilting angle	Total width	Frame width	Frame length	Height	Slots for	Earth return
	kg/lbs	kgm	mm/ inch	mm/ inch	mm/ inch	mm/ inch	mm/ inch	°	mm/ inch	mm/ inch	mm/ inch	mm/ inch		Amp
L500	500/1100	75	750/30	100/4	750/30	500/20	750/30	+/-180	1500/59	800/31	1100/43	2000/79	M16	300
L1000	1000/2200	150	750/30	150/6	750/30	800/31	750/30	+/-180	1800/71	1000/39	1200/47	2500/94	M16	300
L1500	1500/3300	225	1250/49	150/6	1000/39	1200/47	1000/39	+/-180	2600/102	1200/47	1400/55	3000/118	M16	300
L2000	2000/4400	300	1250/49	150/6	1000/39	1200/47	1000/39	+/-180	2800/110	1350/53	1800/71	3200/126	M16	600
L5000	5000/11000	750	1250/49	150/6	1000/39	1300/51	1200/47	+/-180	3000/118	1500/59	2000/79	3800/150	M16	600
L10 000	10 000/22 000	1500	1500/59	200/8	1500/59	1300/51	1500/59	+/-180	3200/126	1650/65	2500/94	4300/169	M16	600
L15 000	15 000/33 000	2250	1500/59	250/10	1500/59	1500/59	1500/59	+/-180	3600/142	1800/71	3000/118	4400/173	M20	600

# H RANGE TURNTABLES

## DESCRIPTION

Turntables of the H-range are used for welding, grinding and positioning purposes.

Infinitely variable turning speed, achieved by an inverter controlled motorgearbox allow ideal possibilities for welding and positioning. Large bearings ensure stability and smooth movement.

## TECHNICAL DATA

### Turning drive

Geared AC-motor, controlled by an inverter is driving the face plate over a ball bearing

### Electrics

230 V, 1 Phase, 50 Hz or 400 V, 3 Phase, 50 Hz



MODEL	CAPACITY kg/lbs	FACE PLATE DIA mm/inch	TURNING SPEED rpm
H 1000	1000/2200	1000/39	0 - 2
H 2000	2000/4400	1100/43	0 - 2
H 5000	5000/11 000	1200/47	0 - 1,5
H 10 000	10 000/22 000	1300/51	0 - 1

*Other than specified sizes available on request*



# TT RANGE TURNTABLES



## DESCRIPTION

Positioners of the TT-range are used for welding, grinding and positioning purposes. Infinitely variable turning speed, achieved by an inverter controlled motorgearbox allows ideal possibilities for welding and positioning. Large bearings ensure stability and smooth movement.

## TECHNICAL DATA

### Turning drive

Geared AC-motor, controlled by an inverter is driving the face plate over pinion and slewing ring.

### Electrics

230 V, 1 Phase, 50 Hz or 400 V, 3 Phase, 50 Hz

Various models in different sizes up to 50000 kg (110000 lbs) load capacity available.

# QCS RANGE

## QUICK CLAMPING SYSTEM

### DESCRIPTION

Alternatively to clamp a workpiece with a manual chuck by a hook wrench, we have developed especially for the welding process our Quick Clamping System for this special purpose.

Instead of the long-winded clamping of the workpiece, the clamping is effected very quickly and efficiently by a manual handwheel.

### TECHNICAL DATA

**Clamping Diameter** up to 250 mm or up to 315 mm

**Weight** approx. 30 kgs

**Application** up to 10 min<sup>-1</sup>, especially for welding on welding-turntables

**Usage** Quick and efficient clamping of the workpiece by the manual handwheel.



# MC RANGE MANUAL CHUCKS

## DESCRIPTION

The MC series manual chucks are designed for heavy duty purposes and have a completely closed housing, therefore this equipment is especially useful for the welding industry.

Features include single point cam operation of the jaws and adjustable quick change reversible jaws. Standard delivery includes steel jaws, hardened jaws are also available.

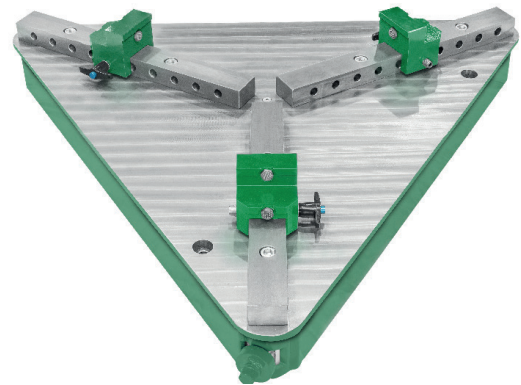

## APPLICATION

Manual chucks of the MC series are used for clamping of workpieces for welding processes.

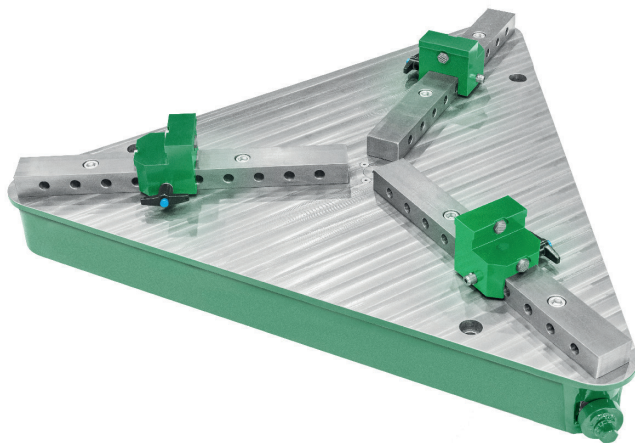

## DIMENSIONS

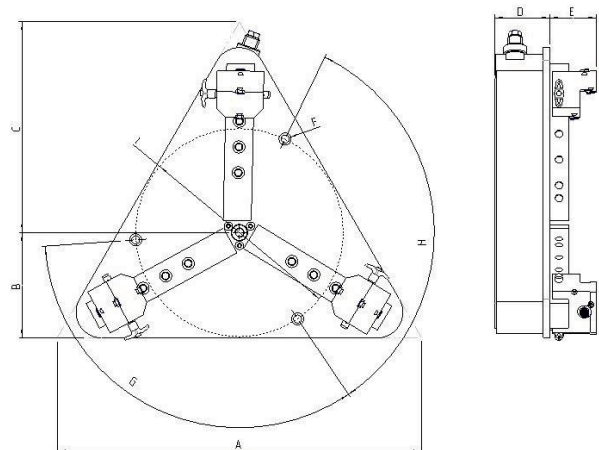

MODEL	CLAMPING DIAMETER		A	B	C	D	E	F	G	H	I
	max.	min.									
MC 700	700	40	770	225	425	118	100	17	120	120	445
MC 1000	1000	40	1160	335	670	118	100	22	120	120	840
MC 1200	1200	40	1160	335	670	118	100	22	120	120	840
MC 1600	1600	40	1492	431	862	118	100	22	120	120	985
MC 1800	1800	40	1492	431	862	118	100	22	120	120	985

# GR RANGE OSCILLATORS FOR WELDING



		GR32	GR33
Oscillating speed (cycle/min.)		150	150
Width of oscillating	Radius 120 mm / 5 inches	0~36 mm / 0~1.4 inches	0~36 mm / 0~1.4 inches
	Radius 180 mm / 7 inches	0~54 mm / 0~2.2 inches	0~54 mm / 0~2.2 inches
	Radius 200 mm / 8 inches	0~60 mm / 0~2.4 inches	0~60 mm / 0~2.4 inches
Left dwell time		-	0~2,1 sec.
Middle dwell time		-	0~2,1 sec.
Right dwell time		-	0~2,1 sec.
Delay start time		0~5,1 sec.	0~5,1 sec.
Max. weight capacity		4 kg / 8 lbs	4 kg / 8 lbs
Power input		DC 24 V	DC 24 V
Power output		20 W	20 W
Dimensions		215 x 180 x 90 mm / 9 x 7 x 4 inches	215 x 180 x 90 mm / 9 x 7 x 4 inches
Weight		1,5 kg / 3 lbs	1,5 kg / 3 lbs
Welding position		vertical, horizontal, over- head and flat position	vertical, horizontal, over- head and flat position

# SCM RANGE PIPE CUTTING MACHINES

## DESCRIPTION

The SCM machines are equipped with two PLC-controlled axis which enables the machine to cut pipes in conjunction with a plasma or oxy-fuel torch.

The work piece is clamped and turned by a driven chuck (axis 1), then the torch is moved over the pipe (axis 2). Optional, a third controlled axis can be added to enable the machine to bevel end cuts (straight, miter and branches).

All programming is menu-driven, the machine is therefore easy to operate.

## APPLICATION

Pipe cutting machines of the SCM range are used for pipe cutting and profiling in the workshop as well as on site



*SCM 630 prepared for Plasma Cutting, with 3rd controlled axis (allows bevelling of end cuts) and 540 mm through hole chuck.*



# SCM RANGE PIPE CUTTING MACHINES

STRAIGHT CUT / MITER CUT



BRANCH SITTING IN MAIN PIPE

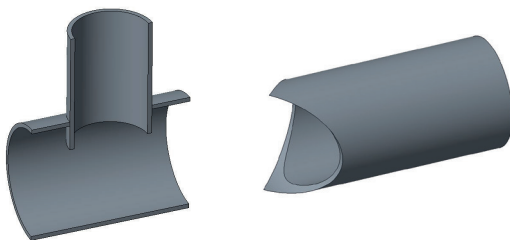

BRANCH SITTING ON MAIN PIPE

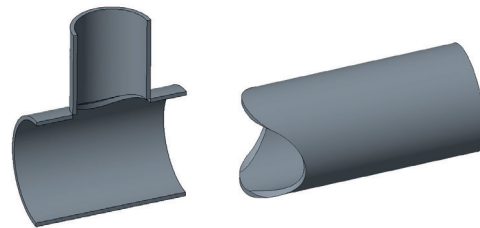

HOLE FOR BRANCH SITTING IN MAIN PIPE

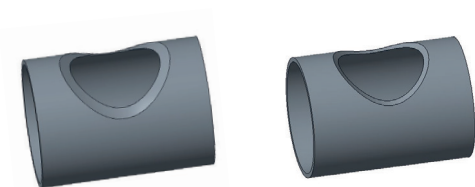

HOLE FOR BRANCH SITTING ON MAIN PIPE

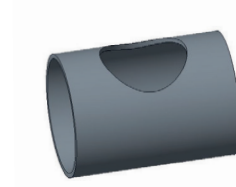

TYPE	WORKPIECE DIAMETER		TORCH STROKE (mm/inch)	THROUGH-HOLE (mm/inch)	CUTTING SPEED (mm/min inch/min)
	min. (mm/inch)	max. (mm/inch)			
SCM 300	25/1	300/12	500/20	100/4	2000/79
SCM 400	25/1	400/16	1000/39	150/6	2000/79
SCM 630	25/1	630/25	1500/59	200/8	2000/79

# SCM RANGE PIPE CUTTING MACHINES

ELBOW SUPPORT



STUD ON DISHED END

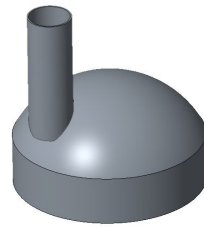

RECTANGLE

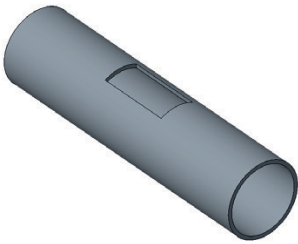

RECTANGLE WITH RADIUS

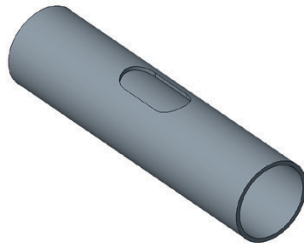

RECTANGLE WITH PROGRAMMABLE RADIUS

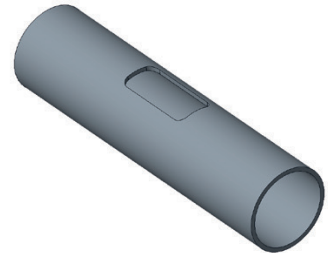

LEFT OPENING

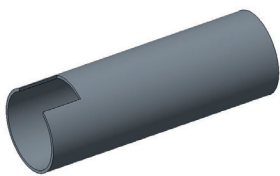

RIGHT OPENING

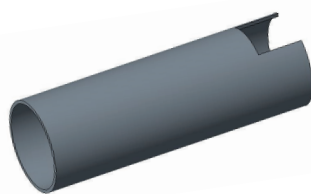

OPENING WITH RADIUS

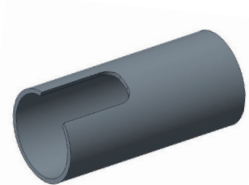

# RSM RANGE CNC-CONTROLLED PIPE CUTTING MACHINE

## DESCRIPTION

Five-axis-CNC-controlled pipe cutting machines of the RSM range are used for cutting of adaption (branches) and penetrations (holes) in pipe and steel construction.

By the combination of five controlled axes (turning of the pipe, longitudinal movement of the torch, tilting and turning of the torch as well as up

and down movement of the torch) and a computer-controlled height sensor, every shape needed in pipeline and steel construction can be manufactured, optional with or without weld seam preparation. Online programming (directly at the machine, menu-driven) and offline programming (in pre-work preparation with network data transfer to the machine) allow perfection of flexibility.

Oxy-fuel cutting and plasma cutting enable the cutting of all kinds of material.





# RSM RANGE CNC-CONTROLLED PIPE CUTTING MACHINE

STRAIGHT CUT / MITER CUT



T-JOINT END CUT  
T-JOIN HOLE CUT

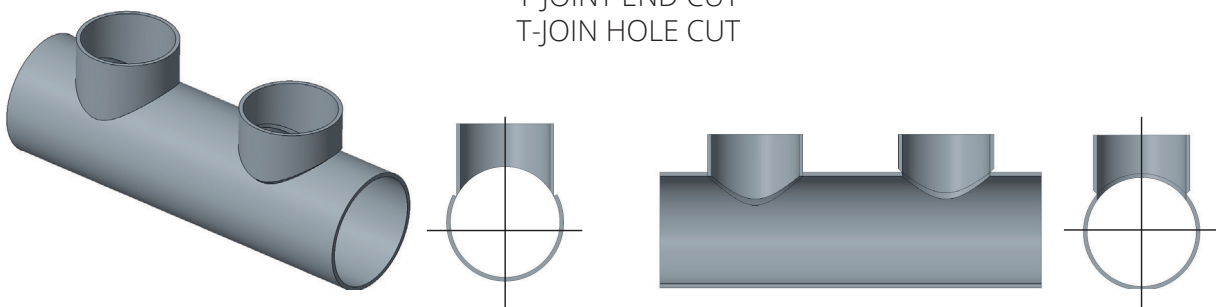

SLANT JOINT END CUT  
SLANT JOINT HOLE CUT

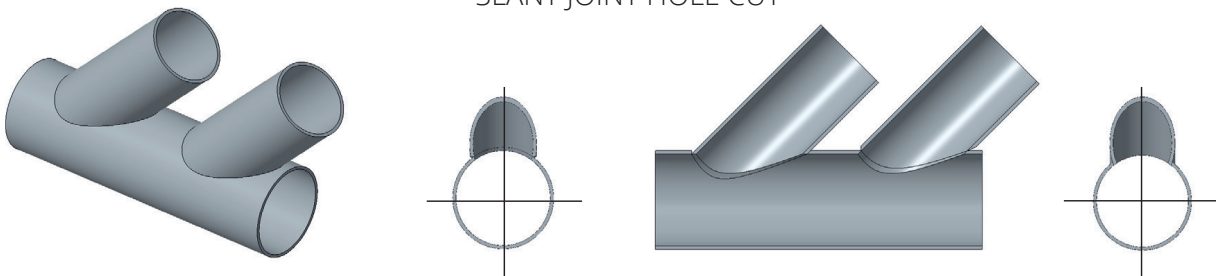

OFF-CENTER SLANT JOINT END CUT  
OFF-CENTER SLANT JOINT HOLE CUTS

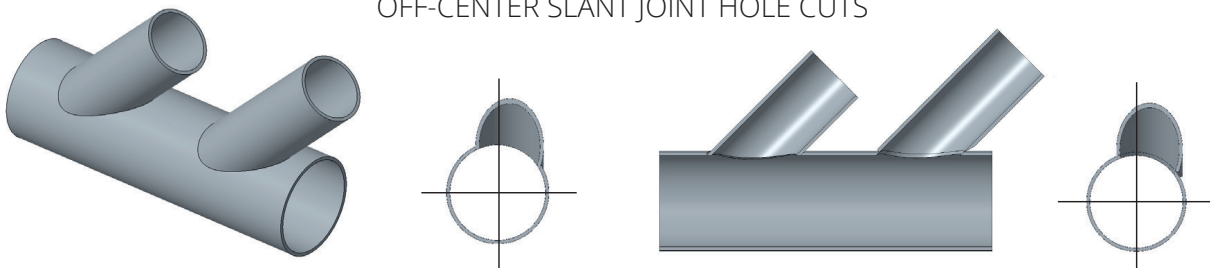

# RMB/TRMB RANGE COLUMN & BOOM MANIPULATOR

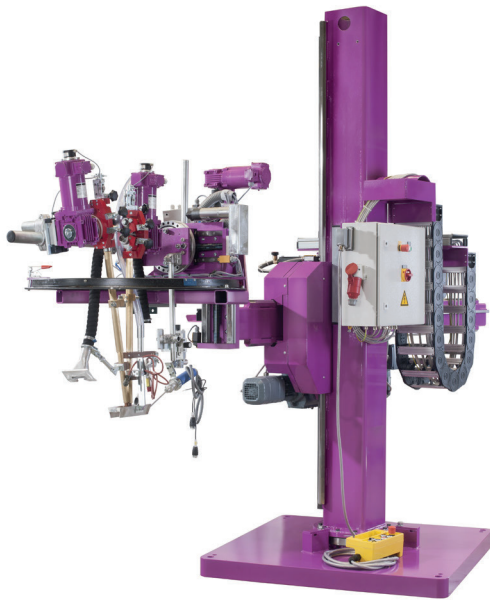

## DESCRIPTION

Globally the Kistler range of Column & Boom Manipulators stands out not only for innovation in design and quality of manufacture, but also for reliability and robustness.

- 360° column rotation with manual locking at any position.
- Variable speed boom.
- Boom elevation through geared motor rack and pinion drive with elektro-magnetic brake.
- Elevation and traverse drive mounted on saddle providing for easy access servicing and maintenance.



- Machines fully counter-balanced by column internal weight, connected to the saddle by heavy duty wire rope. Anti-fall device offers full safety feature.
- Extra wide rollers and unique slideways ensure minimum deflection traversing.
- Innovative machined 'V' ways to column ensure that the boom saddle moves smoothly with no vibration. This reduces wear and tear.

Various models in different sizes  
up to 430 kg (947 lbs) load capacity available.

# RC/TRC RANGE HEAVY DUTY COLUMN & BOOM MANIPULATOR



## DESCRIPTION

The most popular of the ranges of Column & Boom manipulators are the RC (stationary) And TRC (traversing) universal Column and Booms.

These are equipped with motorized elevation, motorized boom traverse and manual, optional motorized rotation.

Maximum Height under Boom ranges from 4000 mm to 6000 mm

Minimum Height under Boom: 1000 mm

Maximum Boom Traverse ranges from: 3000 mm to 5000 mm

Welder's seat is available as an option

# TRC/F RANGE COLUMN & FIXED BOOM MANIPULATOR

## DESCRIPTION

The universal column & boom manipulator with fixed boom is suitable for the following applications:

- Plate joining / splicing
- Beam welding  
(I beams, H beams, tapered beams)
- Box beam welding
- Vessel welding  
(internal, external, longitudinal and circumferential)

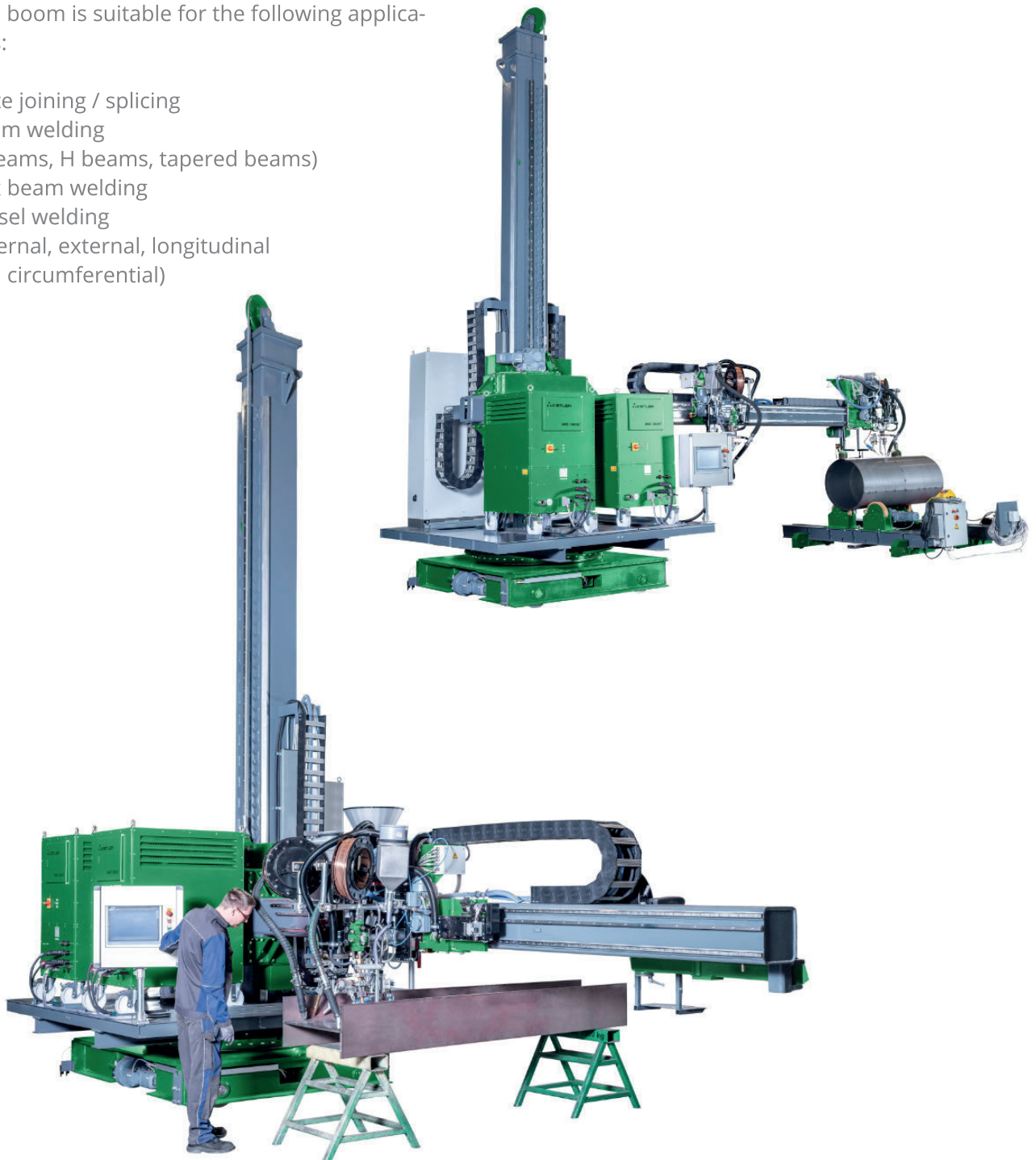

# LBL RANGE

## H BEAM WELDING LINES

### DESCRIPTION

The LBL is a dedicated machine designed for the continuous production of welded I and T Beams, either parallel or tapered.

The LBL operates with the Web plate in the vertical position. No tack weld welding is required except at the leading edge, after the Web has been aligned on the center line of the Flange.

Initially the Web and first Flange are fed into the LBL machine, the welding is carried out simultaneously from both sides of the Web over the full length of the Beam.

After completion of the first Flange welding, the section is turned 180° and the alignment and welding operation repeated with the second Flange.



	1250 MD		2000 MD	
	min.	max.	min.	max.
<b>Web heights</b> in mm/inches	200/8	1250/49	200/8	2000/79
<b>Web thickness</b> in mm/inches	4/0,1	25/1	5/0,2	30/1
<b>Flange width</b> in mm/inches	100/4	600/27	100/4	1000/39
<b>Flange thickness</b> in mm/inches	5/0,2	40/2	6/0,2	50/2
<b>Weight</b> in kg/m lbs/m	-	1000/2205	-	1000/2205
<b>Length</b> in mm/inches	6/0,2	12/0,5	6/0,2	12/0,5

# VBL RANGE H BEAM WELDING LINES

## DESCRIPTION

The VBL is a dedicated machine designed for the continuous production of welded I and T Beams, either parallel or tapered.

The VBL operates with the Web plate in the vertical position.

No tack weld welding is required except at the leading edge, after the Web has been aligned on the center line of the Flange.

Initially the Web and first Flange are feed into the VBL machine, the welding is carried out simultaneously from both sides of the Web over the full length of the Beam.

After completion of the first Flange welding, the section is turned 180° and the alignment and welding operation repeated with the second Flange.

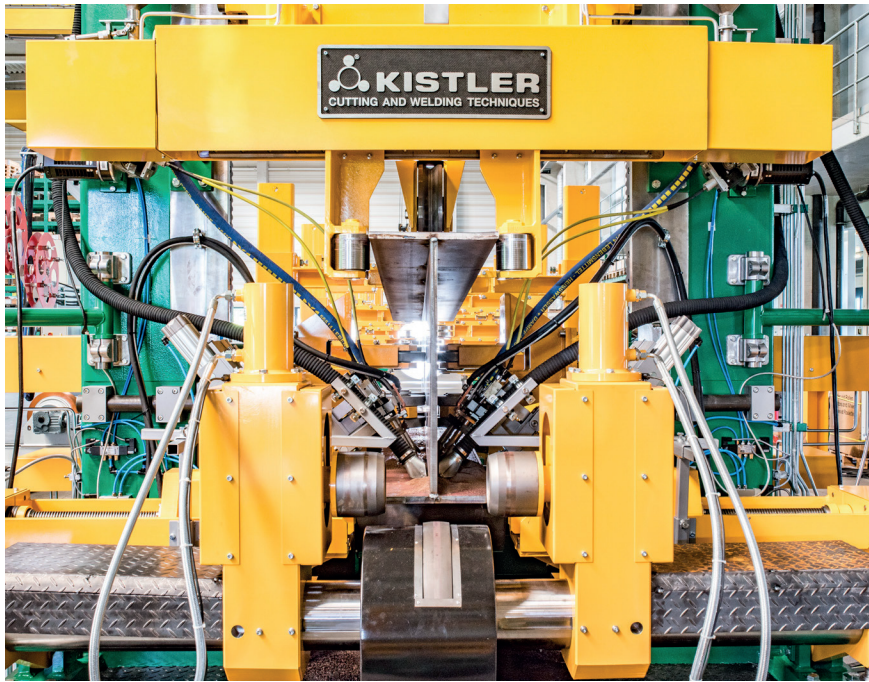

	Small		Medium		Large	
	min.	max.	min.	max.	min.	max.
<b>Web heights</b> in mm/inches	180/7	2000/79	200/8	3000	250/10	5000/197
<b>Web thickness</b> in mm/inches	8/0,3	25/1	8/0,3	30/1	8/0,3	50/2
<b>Flange width</b> in mm/inches	100/4	1000/39	150/6	1250/49	100/4	2000/79
<b>Flange thickness</b> in mm/inches	8/0,3	50/2	8/0,3	50/2	8/0,3	100/4
<b>Weight</b> in kg/m lbs/m		1000/2204		2000/4400		3000/6600
<b>Length</b> in mm/inches	2000/79	25000/984	2000/79	45000/1772	2000/79	45000/1772

# HSW RANGE SEAMWELDING MACHINE

## DESCRIPTION

The Kistler HSW range of Seam Welding machines has been designed for welding longitudinal seams of cylindrical, conical and rectangular workpieces and, in addition, flat sheet or plate.

The robust construction of the machine and patented design of the clamping finger operation ensures the correct alignment for the welding on-gauge material in stainless steel, mild steel, titanium, copper or aluminium. The variable speed travelling carriage which traverses an accurately machined beam ensures the torch follows precisely the welding seam.

The Kistler HSW range will produce uniformly strong welds and reduce welding costs using TIG (Argon Arc), MIG (Metal Inert Gas using Arcon, CO<sub>2</sub> or Gas mixtures) or Submerged Arc processes.

Various models in different sizes available.

## GENERAL SPECIFICATION

- Rigid construction ensuring accurate clamping and workpiece alignment.
- Accomodates conical, cylindrical, flat, rectangular workpieces.
- Patented finger clamping mechanism, fingers supported to give a „rock and roll“ movement, maximum clamp pressure 70 kg/cm each side of fingers.
- Ready horizontal adjustment of fingers to suit welding parameters.
- Replaceable finger tips.
- Clamping pressure readily adjustable by regulator positioned on machine pedestal.
- Backing bar insert designed to give uniform gas flow (optional).
- Precise seam alignment gauges.
- Precision variable speed drive for welding torch carriage.
- Automatic sequence of initiating and ending of weld cycle.
- Limit switches to prevent overrun at each end.
- Foot operated air controls for each row of clamping fingers.
- Backing bars readily interchangeable.
- Rotating mandrels can be provided which incorporate two or more backing bars to facilitate rapid changeover to handle various forms of workpieces.



# SUBMERGED ARC WELDING HEADS

## DESCRIPTION

Subarc Welding Head for longitudinal seam welding with three wires model H-UP-S5, suitable for diameters from 400 mm upwards. Complete with laser pointer, headlamp, height sensor, flux separator, flux pan, flux suction hose and motorized cross slide 80 mm stroke each.

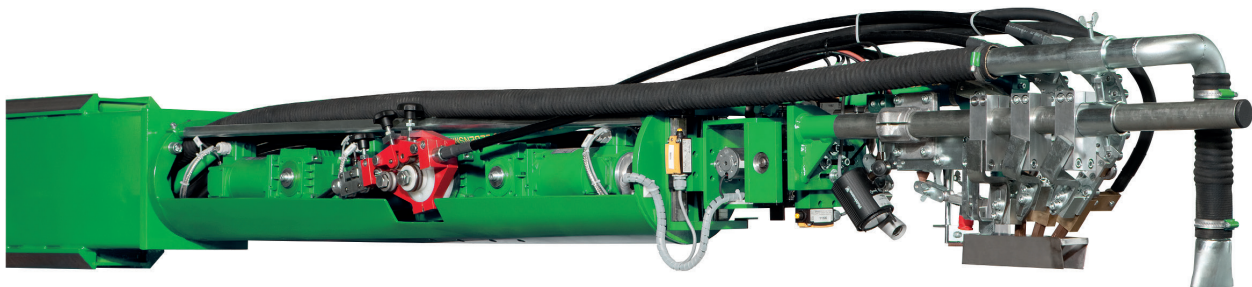

## TECHNICAL DATA

### Welding Head

Maximum Wire diameter: 4 mm  
Maximum Wire diameter (Stainless Steel): 3 mm  
Maximum Current: 1200 A / 1200 A / 1200 A  
Control Voltage: 42 V

### Cross slides

Vertical stroke: 80 mm  
Horizontal Stroke: 80 mm

### Wire Feed Unit

Motor Voltage: 38 V  
Motor speed: 3200 / 36 U/min  
Motor power: 180 W  
Motor torque: 36 Nm  
Maximum wire feed speed: 5,4 m/min



# FLUX FEED AND RECOVERY SYSTEMS

## DESCRIPTION

Flux feed and recovery unit, working in closed loop with circular flow, operated by compressed air.

## TECHNICAL DATA

**Flux content** 8 l

**maximum air pressure** 6 bar

**Dimensions (LxWxH) approx.** 1000 x 200 x 850mm

**Weight approx.** 20 kg



## DESCRIPTION

Flux is fed to the joint from the 8 l flux hopper. The air driven Injektor sucks surplus flux into the separator where flux is separated from dust. Flux falls down into the flux hopper, dust is collected in a filter.

If the MIN sensor mounted in the pressure tank is activated, refilling of the pressure tank is necessary. During this operation, welding can be continued with the 8 l of flux in the flux hopper.

Flux is being fed from the pressure tank to the welding point with approx. 2 bar pressure. In the flux-air-separator, the air exhausts and in case the flux level is lower than the entry level, new flux is added.

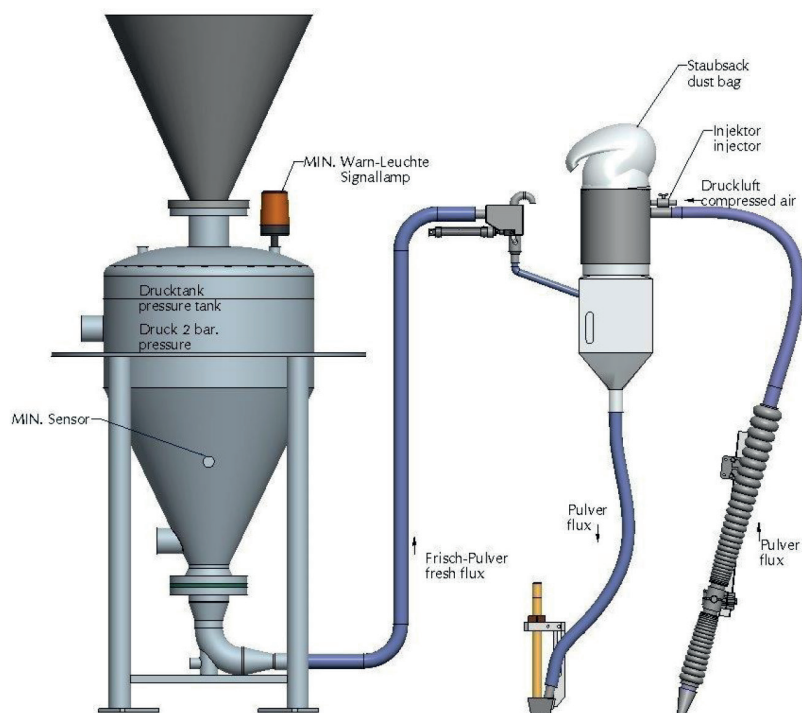

# FLUX FEED AND RECOVERY SYSTEMS

## DESCRIPTION

The pressure tank is being filled manually –optional automatic- with flux with open conical seal via the centrifugal separator until the MAX sensor is activated. After Filling the conical seal is closed.

In operation mode, flux is being fed from the pressure tank to the welding point with approx. 2 bar pressure. In the flux-air-separator, the air exhausts and the flux falls down to the welding joint.

An electric turbine creates a vacuum which sucks the surplus flux from the joint. In the centrifugal separator, flux and dust are separated. Flux falls into the separator, slag remains in the inbuilt wire mesh and dust is being collected in a filter mounted in the turbine.

A closed loop works until the MIN sensor mounted in the pressure tank is activated. Consequently, a refilling process has to be started by switching off the turbine and compressed air and opening the conical seal. Once this is done, surplus plus fresh flux can fall from the separator into the pressure tank.

Capacity of pressure tank and separator can vary, in practical use, 100 l (pressure tank) and 80 l (separator) have proven very useful.

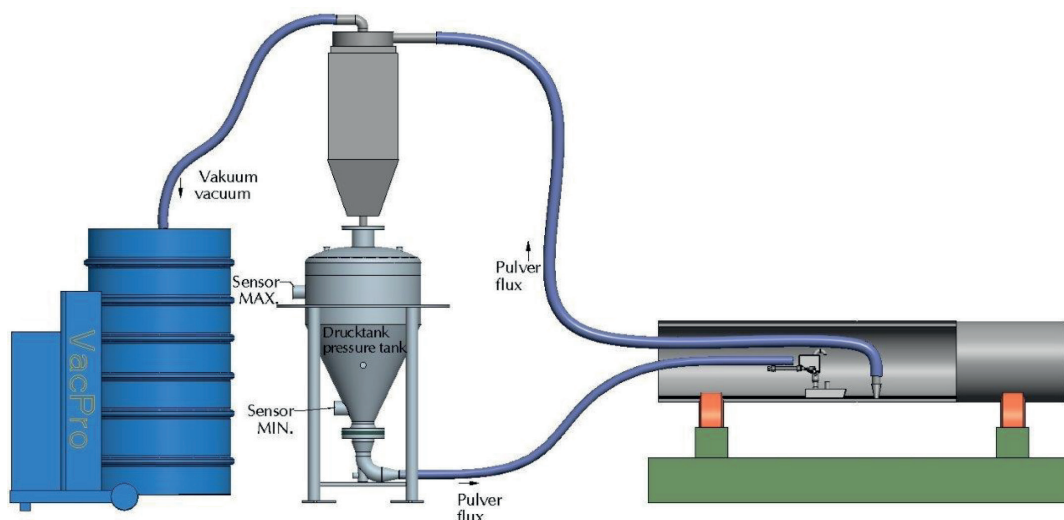

# WIRESMASTER

## DESCRIPTION

WireMaster-SA27 is a revolutionary wire feed system that provides an interruption free wire feed, preventing commonly experienced problems in the subarc welding process. A series of mini-rollers positioned at right angles to the wire travel direction allows for a friction free transport of wires in a variety of diameters types and even combinations. The WireMaster-SA27 presents a solution for copper coated and un-copper coated wires, even when the welding wire has been bent or there is excessive torsional twist. In addition, common wire feed interruptions associated with helix and the wire surface are also eliminated with the WireMaster-SA27.

The image 1a illustrates the protective sleeve housing the straightening system comprised of patented individual mini-rollers segments. Due to the unique construction of this system it is possible to quickly increase or decrease the length of the

WireMaster-SA27 as well as to perform quick local maintenance should a segment become damaged on the shop floor. The segment system also allows enables the for quick a connect-disconnect process that enables maintenance as well as the welders easy access to the segment and the replacement of mini-roller segments and the protective sleeve.

In the images above the internal mechanics are visible, including the patented roller system that provides an unrestricted transport of the welding wire. The image above right illustrates the individual roller segments inside of the protective sleeve, prior to final fitting. WireMaster-SA27 was primarily designed for subarc welding applications. This system is ideal for feeding wires up to 5 mm in diameter; additionally it is possible to feed two wire simultaneously for tandem wire applications (see image 3).

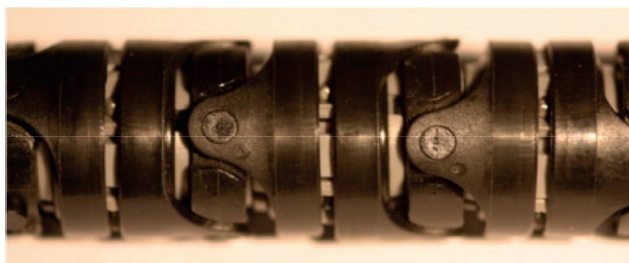

1a: Without sleeve protective sleeveImage



Image 1b: Surface of straighteners with sleeveImage



Image 2a:  
cross section



Image 2b: Roller System and protective sleeve.



Image 3: A range of possibilities are possible: single wire and tandem wires (Twinarc®)

# OAWC RANGE WELDING CAMERA

## DESCRIPTION

The OAWC (Open Arc Welding Camera) delivers a sharp color image for optimal viewing of the welding head, wire feeder, and workpiece, as well as arc, reflow, etc.

With the help of a keyboard, image detail, sharpness, and brightness can be quickly and easily adjusted before, during, and after the welding process. Thus, for example, the set-up time can be significantly shortened or possible welding errors can be detected more quickly.

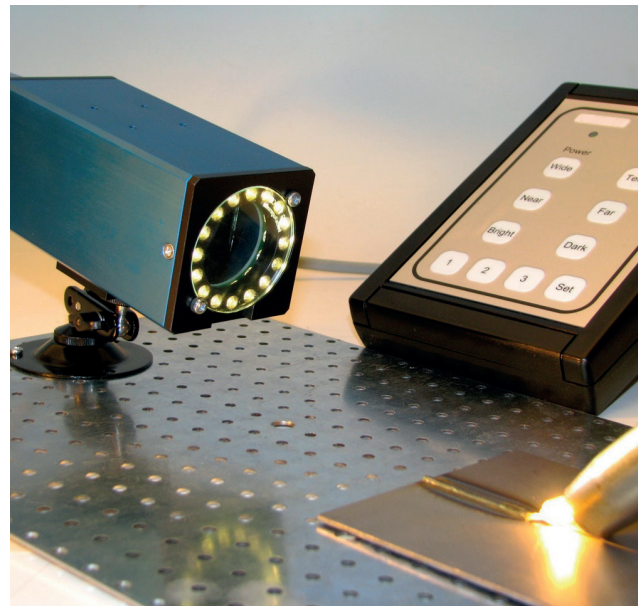

## TECHNICAL DATA

### Sensor:

1/4 „ExView HAD CCD, 460 TV Lines,  
752 x 582 pixels, 440k pixels

### Lens:

10x optical zoom  
f = 4,2mm, opening angle 46 °, wide  
f = 42mm, opening angle 4,6 °, tele

Shutter: fixed at 1/50 sec.

Aperture: adjustable from F = 1.8 to F = 28

Gain: -3 dB to 28 dB in 2 dB increments

### Video output:

CVBS, 1 V p\_p (sync. Negative)  
Automatic white balance, ATW  
Manual focusing for optimal focusing  
2 memory locations for parameter settings  
Camera control cable up to max. 50m

### Power supply:

12 VDC, 220 mA, via included power  
supply unit with input voltage range from  
100 to 240 VAC

Operating temperature: 0 ... 50 ° C

### Dimensions:

Camera 60 x 60 x 140 mm,  
Control unit 135 x 190 x 55 mm (W x D x H)

Weight: Camera about 650 gr.

# TURNKEY SYSTEMS

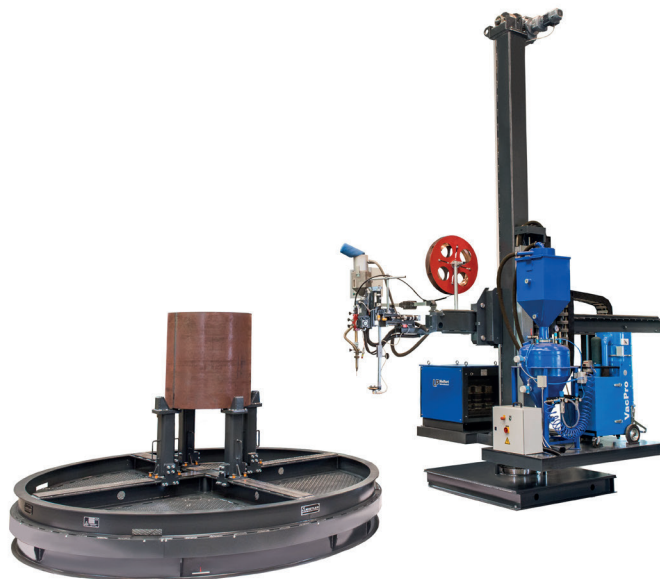
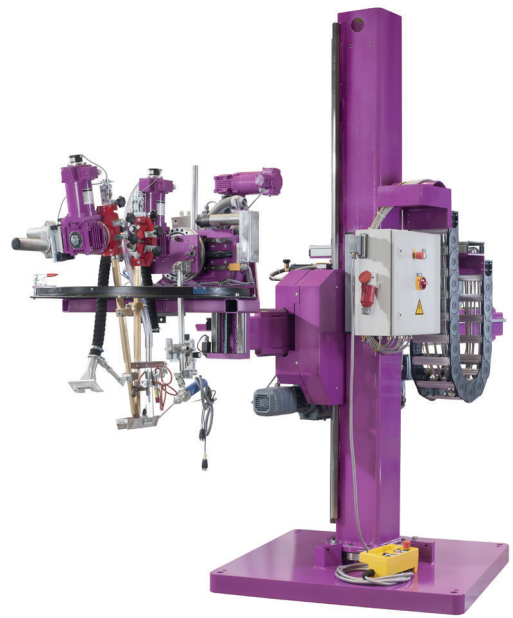



# TEAM



It is the intent of KISTLER  
to provide quality welding  
positioning and cutting equipment  
to the welding industry at a reasonable  
price to a mutually acceptable schedule.  
The special is our standard!









## THE KISTLER MACHINE COMPANY

is a long established family business engaged in engineering and manufacturing of welding positioning and cutting systems for the welding trade, especially for pipe welding and cutting.

In order to serve the customer's need best, KISTLER will not only supply a large range of standard equipment (such as positioners, turning rolls, manipulators etc.) but also design and manufacture automation equipment according to customer's specific needs.

**More detailed brochures are available for all products.**



**Kistler Maschinen-  
und Anlagenbau GmbH**

Mackstrasse 84

D-88348 Bad Saulgau, Germany

Tel +49 (0) 75 81 4 88 82-0

Fax +49 (0) 75 81 4 88 82-22

info@kistler-machine.de

www.kistler-machine.de